

E1NM

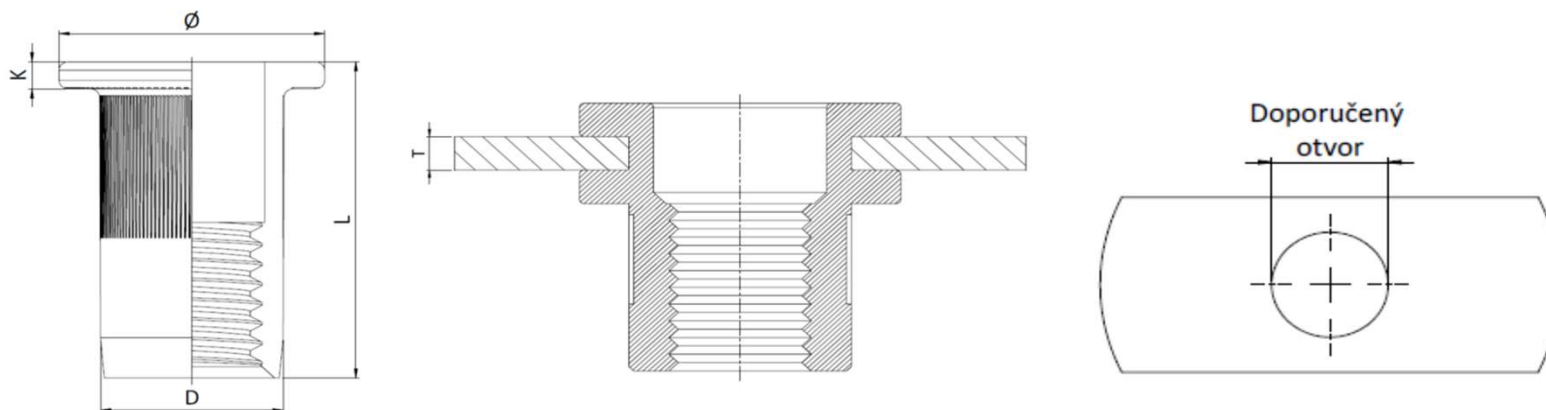

nerezová nitovacia matica, zapustená hlava, ryhovaný driek, AISI304

Označenie	Závit	Hrúbka plechu Min - Max T[mm]	Doporučený otvor +0.1 / 0 [mm]	D [mm]	Ø [mm]	K [mm]	L [mm]
E1-NM5	M5x0.8	1.5-4.0	7.0	6.9	10.0	1.7	13.0
E1-NM6	M6x1.0	1.5-4.5	9.0	8.9	12.0	1.7	16.0
E1-NM8	M8x1.25	1.5-4.5	11.0	10.9	14.0	1.7	19.0
E1-NM10	M10x1.5	1.5-4.5	13.0	12.9	16.0	1.7	21.0