

TURBO

50 - 80 - 120 - 160

Motoriduttori per scorrevoli
Gear-motor for sliding gates
Motoreducteur pour coulissants
Motorreductores para rejas correderas
Getriebe für Schiebegitter
Motorreductores para portões de correr
Napęd silnikowy do bram przesuwanych



Management
System
ISO 9001:2008

www.tuv.com
ID 9105043769

1	Safety warnings	pag. 11
2	Product overview	pag. 12
2.1	Product description	pag. 12
2.2	Set panel and technical characteristics	pag. 12
3	Preliminary checks	pag. 14
4	Installing the product	pag. 14
4.1	Manual running	pag. 14
4.2	Installing	pag. 14
4.3	Fixing	pag. 15
4.4	Rack assembling	pag. 15
4.5	Limit switch fixing	pag. 16
5	Testing and commissioning	pag. 16
5.1	Testing	pag. 16
5.2	Commissioning	pag. 16
6	Instructions and warnings for the end user	pag. 17
7	EC Declaration of Conformity	pag.59

1 - SAFETY WARNINGS

CAUTION – ORIGINAL INSTRUCTIONS - important safety instructions. Compliance with the safety instructions below is important for personal safety. Save these instructions.

Read the instructions carefully before proceeding with installation.

The design and manufacture of the devices making up the product and the information in this manual are compliant with current safety standards. However, incorrect installation or programming may cause serious injury to those working on or using the system. Compliance with the instructions provided here when installing the product is therefore extremely important.

If in any doubt regarding installation, do not proceed and contact the Key Automation Technical Service for clarifications.

Under European legislation, an automatic door or gate system must comply with the standards envisaged in the Directive 2006/42/EC (Machinery Directive) and in particular standards EN 12445; EN 12453; EN 12635 and EN 13241-1, which enable declaration of presumed conformity of the automation system.

Therefore, final connection of the automation system to the electrical mains, system testing, commissioning and routine maintenance must be performed by skilled, qualified personnel, in observance of the instructions in the "Testing and commissioning the automation system" section.

The aforesaid personnel are also responsible for the tests required to verify the solutions adopted according to the risks present, and for ensuring observance of all legal provisions, standards and regulations, with particular reference to all requirements of the EN 12445 standard which establishes the test methods for testing door and gate automation systems.

WARNING - Before starting installation, perform the following checks and assessments:

ensure that every device used to set up the automation system is suited to the intended system overall. For this purpose, pay special attention to the data provided in the "Technical specifications" section. Do not proceed with installation if any one of these devices is not suitable for its intended purpose;

check that the devices purchased are sufficient to guarantee system safety and functionality;

perform a risk assessment, including a list of the essential safety requirements as envisaged in Annex I of the Machinery Directive, specifying the solutions adopted. The risk assessment is one of the documents included in the automation system's technical file. This must be compiled by a professional installer.

Considering the risk situations that may arise during installation phases and use of the product, the automation system must be installed in compliance with the following safety precautions:

never make modifications to any part of the automation system other than those specified in this manual. Operations of this type can only lead to malfunctions. The manufacturer declines all liability for damage caused by unauthorised modifications to products;

if the power cable is damaged, it must be replaced by the manufacturer or its after-sales service, or in all cases by a person with similar qualifications, to prevent all risks;

do not allow parts of the automation system to be immersed in water or other liquids. During installation ensure that no liquids are able to enter the various devices;

should this occur, disconnect the power supply immediately and contact a Key Automation Service Centre. Use of the automation system in these conditions may cause hazards;

never place automation system components near to sources of heat or expose them to naked lights. This may damage system components and cause malfunctions, fire or hazards;

all operations requiring opening of the protective housings of various automation system components must be performed with the control unit disconnected from the power supply. If the disconnect device is not in a visible location, affix a notice stating: "MAINTENANCE IN PROGRESS":

connect all devices to an electric power line equipped with an earthing system;

the product cannot be considered to provide effective protection against intrusion. If effective protection is required, the automation system must be combined with other devices;

the product may not be used until the automation system "commissioning" procedure has been performed as specified in the "Automation system testing and commissioning" section;

the system power supply line must include a circuit breaker device with a contact gap allowing complete disconnection in the conditions specified by class III overvoltage;

use unions with IP55 or higher protection when connecting hoses, pipes or cable glands;

the electrical system upstream of the automation system must comply with the relevant regulations and be constructed to good workmanship standards;

users are advised to install an emergency stop button close to the automation system (connected to the control PCB STOP input) to allow the door to be stopped immediately in case of danger;

this device is not intended for use by persons (including children) with impaired physical, sensory or mental capacities, or with lack of experience or skill, unless a person responsible for their safety provides surveillance or instruction in use of the device;

before starting the automation system, ensure that there is no-one in the immediate vicinity;

before proceeding with any cleaning or maintenance work on the automation system, disconnect it from the electrical mains;

special care must be taken to avoid crushing between the part operated by the automation system and any fixed parts around it;

children must be supervised to ensure that they do not play with the equipment.

WARNING - The automation system component packaging material must be disposed of in full observance of current local waste disposal legislation.

WARNING - The data and information in this manual are subject to modification at any time, with no obligation on the part of Key Automation S.r.l. to provide notice.

2 - INTRODUCING THE PRODUCT

2.1 - Product description

Irreversible electromechanical gearmotor for sliding gates operating at 24 Vdc and 230 Vac.

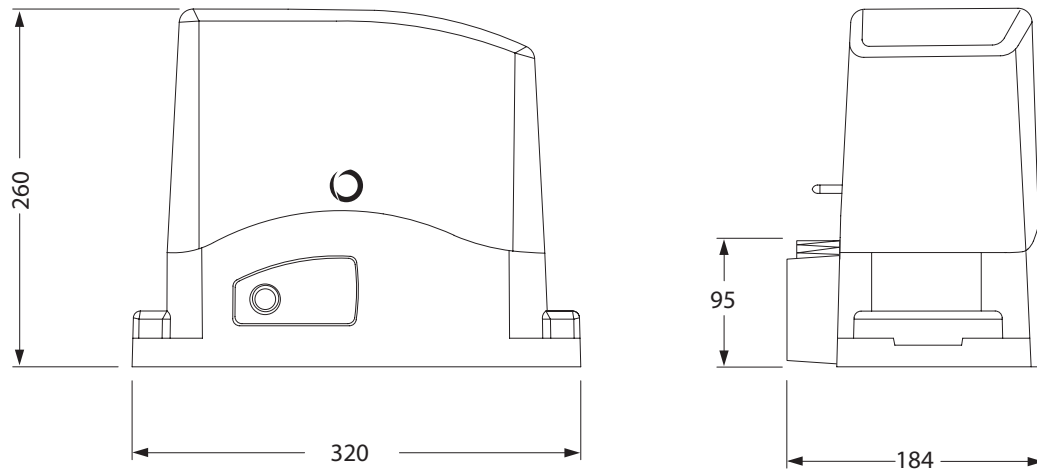

2.2 - Set panel and and technical characteristics

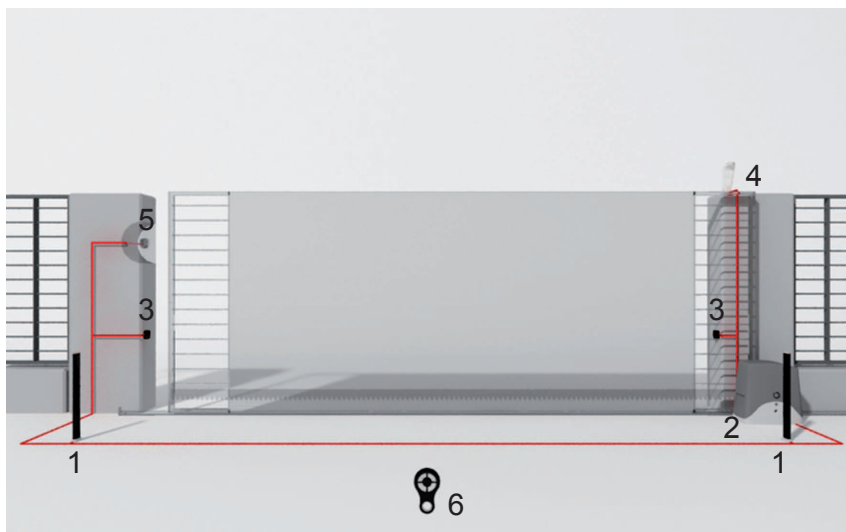

STANDARD INSTALLATION

- 1 Post for photocells
- 2 Automation electromechanical
- 3 Photocell detectors
- 4 Flashing light
- 5 Key switch
- 6 Radio transmitter

TECHNICAL DATA		TURBO 50	TURBO 50
Model		SC-40	SC52
Speed*	cm/s	16	16
Torque	Nm	16	16
Working cycle	%	30	30
Control unit		-	CT102
Power	Vac (Vdc)	230	230
Motor consumption	A	1,3	1,3
Consumption power	W	300	300
Capacitor	µF	12,5	12
Thermoprotection	°C	150	150
Protection degree	IP	44	44
dimension (L - P- H)	mm	320 - 184 - 260	320 - 184 - 260
Weight	kg	12	12,5
Working temperature	°C	-20 +55	-20 +55
Max gate weight	kg	500	800

TECHNICAL DATA		TURBO 80	TURBO 80	TURBO 80
Model		SC-50	SC82	SC7224
Speed*	cm/s	16	16	30
Torque	Nm	29	29	34
Working cycle	%	30	30	80
Control unit		-	CT102	CT10224
Power	Vac (Vdc)	230	230	230 (24)
Motor consumption	A	1,9	1,9	2,5
Consumption power	W	450	450	500
Capacitor	µF	16	16	-
Thermoprotection	°C	150	150	-
Protection degree	IP	44	44	44
dimension (L - P- H)	mm	320 - 184 - 260	320 - 184 - 260	320 - 184 - 260
Weight	kg	12,5	12,5	11
Working temperature	°C	-20 +55	-20 +55	-20 +55
Max gate weight	kg	800	800	700

TECHNICAL DATA		TURBO 120	TURBO 120	TURBO 120
Model		SC-70	SC122	SC11224
Speed*	cm/s	16	16	23
Torque	Nm	40	40	50
Working cycle	%	30	30	80
Control unit		-	CT102	CT10224
Power	Vac (Vdc)	230	230	230 (24)
Motor consumption	A	2,6	2,6	2,3
Consumption power	W	600	600	450
Capacitor	µF	20	20	-
Thermoprotection	°C	150	150	-
Protection degree	IP	44	44	44
dimension (L - P- H)	mm	320 - 184 - 260	320 - 184 - 260	320 - 184 - 260
Weight	kg	13,5	13,5	11
Working temperature	°C	-20 +55	-20 +55	-20 +55
Max gate weight	kg	1200	1200	1100

TECHNICAL DATA		TURBO 160	TURBO 160
Model		SC-100	SC162
Speed*	cm/s	16	16
Torque	Nm	40	40
Working cycle	%	30	30
Control unit		-	CT102
Power	Vac (Vdc)	230	230
Motor consumption	A	3	3
Consumption power	W	700	700
Capacitor	µF	20	20
Thermoprotection	°C	150	150
Protection degree	IP	44	44
dimension (L - P- H)	mm	320 - 184 - 260	320 - 184 - 260
Weight	kg	14,5	14,5
Working temperature	°C	-20 +55	-20 +55
Max gate weight	kg	1600	1600

* Variable data according to gate weight

3 - PRELIMINARY CHECKS

Before the installation starts, we suggest to carry out following inspections and operations:

the gate framework must be strong and suitable;

the gate must not show too many sideways slide skids during the running;

the system of wheels/lower rail and roller/upper runner must work without too many frictions;

to avoid the gate derailment you must install the stop beats of the sliding, whether at the opening or closing, and a second upper roller/runner in full observance of the current law;

remove any manual lock in the beforehand gates;

take on the gate bottom the feed raceway of the feeding cables ($\varnothing 25-50\text{mm}$) and of external connection (photo-cell, flash-light, key selector, etc...).

4 - INSTALLING THE PRODUCT

4.1 - Manual running

Insert the key and turn it 90° in anticlockwise direction.

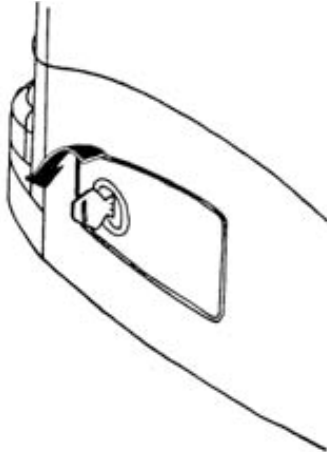

Pull the knob till it is perpendicular to the gearmotor.

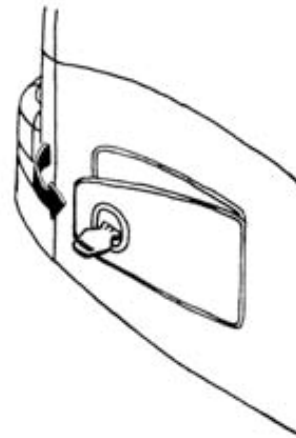

Fig. 2

N.B. Take care to re-engage the gearmotor before starting it up. Engaging with the motor running may damage its internal components.

4.2 - Installing

Respecting the overall size, fix to ground the base-plate through 4 sturdy screw-anchors (fig.3) or down it into the concrete (fig.4).

Plan for one or more sheathing for the passage of the power lines.

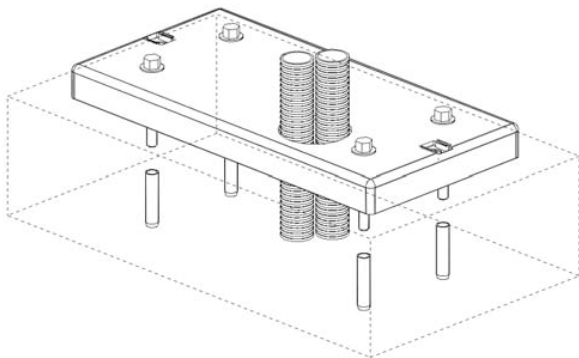

Fig. 3

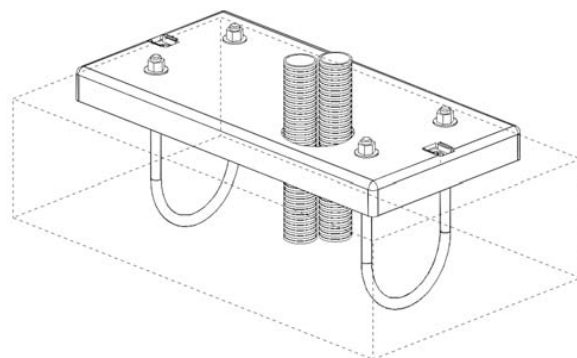

Fig. 4

N.B. The exact dimensions of the rack must be known to allow precise calculation of the counterplate position.

4.3 - Fixing

Take the lid off unscrewing the screws (fig.5). Put the gearmotor on the plate. Insert the two socket head screws (fig.6).

It is important to lock the two socket head screws forcefully, making sure, that the gearmotor is steady on the ground, during the whole gate running.

If the regulating allowed by the rack is not sufficient, it is possible to counterbalance the gearmotor high working on the four screws (fig.7).

The screws should be tightened again after the motor has been operated a few times.

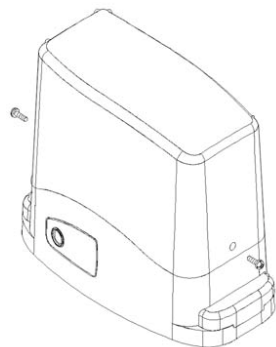

Fig. 5

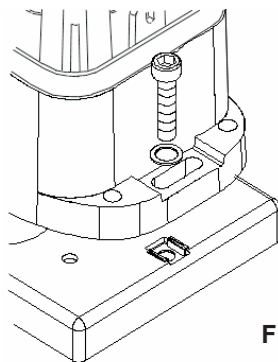

Fig. 6

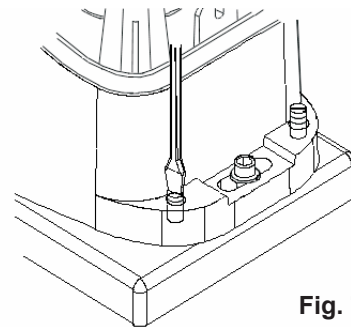

Fig. 7

4.4 - Rack assembling

Release the gearmotor as indicated by the fig.2 and open entirely the gate.

Put a rack element on the pinion gear and fasten it to the gate with screw and spacing bars.

Move the gate manually bringing the pinion gear into line with the last spacing bar.

Fasten the rack element for good.

For a correct positioning of the other elements and to assure their straightness, it is necessary to employ a rack element using it as support and reference (fig.9).

It is besides necessary to assure an aperture of 2 mm between rack and pinion gear, so that the gate weight doesn't rest on the gearmotor pinion gear (fig.8).

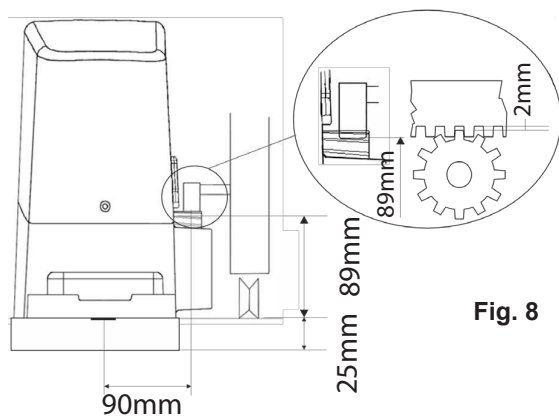

Fig. 8

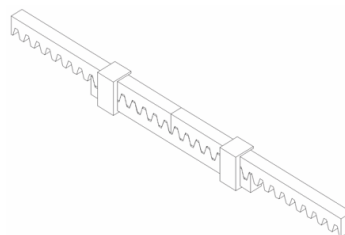

Fig. 9

4.5 - Limit switch fixing

The gate has to be equipped with stop locks at the opening and closing, which prevent the gate derailment.

The stop lock position must assure that the limit switch brackets don't collide with the pinion gear.

Haul the gate manually at the opening leaving, depending on the

gate weight, a crack from 30 to 50 mm between the main gate and mechanical stop.

Fasten the limit switch bracket through the dowels (fig.11) so that the limit switch is pressed (fig.10).

Repeat the operation with the main gate at the closing.

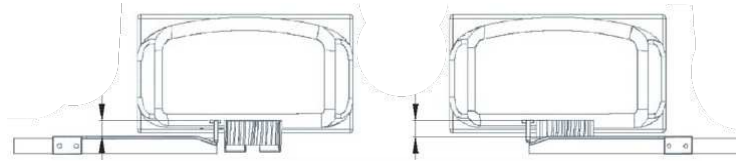

Fig. 10

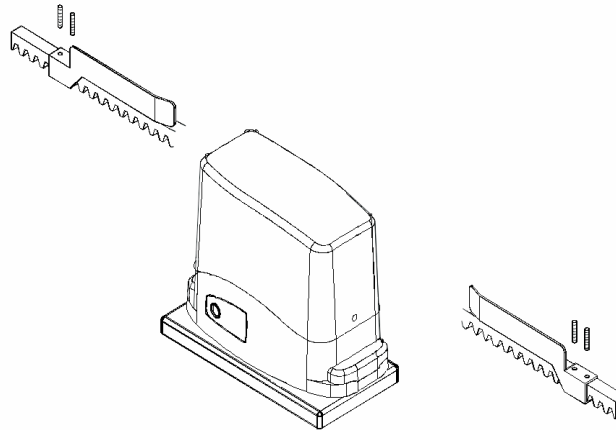

Fig. 11

5 - TESTING AND COMMISSIONING THE AUTOMATION SYSTEM

The system must be tested by a qualified technician, who must perform the tests required by the relevant standards in relation to the risks present, to check that the installation complies with

the relevant regulatory requirements, especially the EN12445 standard which specifies the test methods for gate and door automation systems.

5.1 - Testing

All system components must be tested following the procedures described in their respective operator's manuals;

ensure that the recommendations in Chapter 1 - Safety Warnings - have been complied with;

check that the gate or door is able to move freely once the automation system has been released and is well balanced, meaning that it will remain stationary when released in any position;

check that all connected devices (photocells, sensitive edges, emergency buttons, etc.) are operating correctly by performing gate or door opening, closing and stop tests using the connected control devices (transmitters, buttons or switches);

perform the impact measurements as required by the EN12445 standard, adjusting the control unit's speed, motor force and deceleration functions if the measurements do not give the required results, until the correct setting is obtained.

5.2 - Commissioning

Once all (and not just some) of the system devices have passed the testing procedure, the system can be commissioned;

the system's technical dossier must be produced and kept for 10 years. It must contain the electrical wiring diagram, a drawing or photograph of the system, the analysis of the risks and the solutions adopted to deal with them, the manufacturer's declaration of conformity for all connected devices, the operator's manual for every device and the system maintenance plan;

fix a dataplate with the details of the automation, the name of the person who commissioned it, the serial number and year of construction and the CE marking on the gate or door;

also fit a sign specifying the procedure for releasing the system by hand;

draw up the declaration of conformity, the instructions and precautions for use for the end user and the system maintenance plan and consign them to the end user;

ensure that the user has fully understood how to operate the system in automatic, manual and emergency modes;

the end user must also be informed in writing about any risks and hazards still present;

WARNING - after detecting an obstacle, the gate or door stops during its opening travel and automatic closure is disabled; to restart operation, the user must press the control button or use the transmitter.

6 - INSTRUCTIONS AND WARNINGS FOR THE END USER

Key Automation S.r.l. produces systems for the automation of gates, garage doors, automatic doors, roller blinds and car-park and road barriers. However, Key Automation is not the manufacturer of your complete automation system, which is the outcome of the analysis, assessment, choice of materials and installation work of your chosen installer. Every automation system is unique, and only your installer has the experience and skill required to produce a safe, reliable, durable system tailored to your needs, and above all that complies with the relevant regulatory standards. Although your automation system complies with the regulation safety level, this does not rule out the presence of "residual risk", meaning the possibility that hazards may occur, usually due to reckless or even incorrect use. We would therefore like to give you some advice for the correct use of the system:

- before using the automation system for the first time, have the installer explain the potential causes of residual risks to you;
- keep the manual for future reference, and pass it on to any new owner of the automation system;
- reckless use and misuse of the automation system may make it dangerous: do not operate the automation system with people, animal or objects within its range of action;
- a properly designed automation system has a high level of safety, since its sensor systems prevent it from moving with people or obstacles present so that its operation is always predictable and safe. However, as a precaution children should not be allowed to play close to the automation system, and to prevent involuntary activation, remote controls must not be left within their reach;
- as soon as any system malfunction is noticed, disconnect the electricity supply and perform the manual release procedure. Never attempt repairs on your own; call in your installation engineer. In the meantime the door or gate can be operated without automation once the geared motor has been released using the release key supplied with the system. In the event of safety devices out of service arrange for repairs to the automation immediately;
- in the event of malfunctions or power failures: while waiting for the engineer to come (or for the power to be restored if your system is not equipped with buffer batteries), the door or gate can be used just like any non-automated installation. To do this, the manual release procedure must be carried out;
- manual release and operation: first bear in mind that the release procedure can only be carried out with the door or gate stationary.

- Maintenance: Like any machine, your automation system needs regular periodic maintenance to ensure its long life and total safety. Arrange a periodic maintenance schedule with your installation engineer. Key Automation recommends that maintenance checks should be carried out every six months for normal domestic use, but this interval may vary depending on the level of use. Any inspection, maintenance or repair work must only be carried out by qualified staff.

- Never modify the automation system or its programming and setup parameters: this is the responsibility of your installation engineer.

- Testing, routine maintenance and any repairs must be recorded by the person who performs them and the documents must be conserved by the system's owner.

The only procedures you are capable of, and which you are recommended to perform, are cleaning of the photocell glass and removal of any leaves or stones that may obstruct the automation system. To prevent anyone from activating the gate or door, release the automation system before starting. Clean only with a cloth dipped in a little water.

At the end of its useful life, the automation system must be dismantled by qualified personnel, and the materials must be recycled or disposed of in compliance with the legislation locally in force.

If after some time your remote control seems to have become less effective, or stops operating completely, the battery may be flat (depending on the level of use, this may take from several months up to more than a year). You will realise this because the transmission confirmation light does not come on, or only lights up for a very short time.

Batteries contain pollutants: do not dispose of them with normal waste but follow the methods specified by the local regulations.

Thank you for choosing Key Automation S.r.l.; please visit our Internet site www.keyautomation.it for further information.

DICHIARAZIONE DI INCORPORAZIONE DI QUASI-MACCHINA
DECLARATION OF INCORPORATION OF PARTLY COMPLETED MACHINERY

Il sottoscritto Nicola Michelin, Amministratore Delegato dell'azienda
The undersigned Nicola Michelin, General Manager of the company

Key Automation srl, Via Alessandro Volta, 30 - 30020 Noventa di Piave (VE) – ITALIA

dichiara che il prodotto tipo:
declares that the product type:

TURBO

Motoriduttore elettromeccanico irreversibile per cancelli scorrevoli da 300Kg a 2500Kg
Electromechanical irreversible gear motor for sliding gates from 300Kg to 2500Kg

Models:
Models:

900SC-30CSM
900SC7224, 900SC11224
900SC-40, 900SC-50, 900SC-70, 900SC-100, 900SC52, 900SC52M, 900SC82, 900SC82M, 900SC122,
900SC122M, 900SC162, 900SC162M, 900SC202MHD, 900SC252M, 900SC256M

E' conforme a quanto previsto dalle seguenti direttive comunitarie:
Is in conformity with the following community (EC) regulations:

Direttiva macchine / *Machinery Directive 2006/42/EC*
Direttiva bassa tensione / *Low voltage Directive 2006/95/EC*
Direttiva compatibilità elettromagnetica / *EMC Directive 2004/108/EC*

Secondo quanto previsto dalle seguenti norme armonizzate:
In accordance with the following harmonized standards regulations:

EN 55014-1 + EN 55014-2
EN 61000-3-2 + EN 61000-3-3
EN 61000-6-1 + EN 61000-6-2 + EN 61000-6-3 + EN 61000-6-4
EN 60335-1:2002 + A11:2004 + A1:2004 + A12:2006 + A2:2006 + A13:2008 + A14:2010 + A15:2011
EN 55022

Dichiara che la documentazione tecnica pertinente al prodotto è stata redatta conformemente a quanto previsto dalla direttiva 2006/42/CE Allegato VII parte B e verrà fornita a fronte di una richiesta adeguatamente motivata dalle autorità nazionali.

Declares that the technical documentation is compiled in accordance with the directive 2006/42/EC Annex VII part B and will be transmitted in response to a reasoned request by the national authorities.

Dichiara altresì che non è consentita la messa in servizio del prodotto finché la macchina, in cui il prodotto è incorporato, non sia stata dichiarata conforme alla direttiva 2006/42/CE.

He also declares that is not allowed to use the above mentioned product until the machine, in which this product is incorporated, has been identified and declared in conformity with the regulation 2006/42/EC.

Noventa di Piave (VE), 14/07/14

Amministratore Delegato
General Manager
Nicola Michelin



Key Automation S.r.l. a socio unico
Via A. Volta, 30
30020 Noventa di Piave (VE)
P.IVA 03627650264 C.F. 03627650264
info@keyautomation.it

Capitale sociale 100.000,00 i.v.
Reg. Imprese di Venezia 03627650264
REA VE 326953
www.keyautomation.it



Organizzazione con sistema di gestione certificato
ISO 9001:2008

Key Automation S.r.l.

Via A. Volta 30 - 30020 Noventa di Piave (VE)

T. +39 0421.307.456 - F. +39 0421.656.98

info@keyautomation.it - www.keyautomation.it

Instruction version
580ISSC-50 REV.06