

## FAST AUTOMATIC BARRIERS

FA00028-EN



Official Partner



MILANO 2015  
FEEDING THE PLANET  
ENERGY FOR LIFE



INSTALLATION AND OPERATION

# G3000 - G3000I

EN English



**WARNING!**  
**important safety instructions for people:**  
**READ CAREFULLY!**



**Premise**

• This product should only be used for the purpose for which it was explicitly designed. Any other use is dangerous. CAME S.p.A. is not liable for any damage caused by improper, wrongful and unreasonable use. • The safety of this product and its proper fitting depends, therefore, on respecting its technical characteristics and proper fitting, to be done in state-of-the-art fashion, and under safe conditions as expressly explained in the literature that comes with the product. • Keep these warnings together with the installation and operation manuals that come with the operator.

**Before installing**

*(checking what's there: if something is missing, do not continue until you have complied with all safety provisions)*

• Fitting and testing must be only performed by qualified technicians • Laying the cables, installation and testing must follow state-of-the-art procedures as dictated by standing regulations • Before beginning any operation it is mandatory to carefully read all instructions; improper installation may result in serious harm to people and things • Make sure the boom is in good mechanical state, balanced and aligned, and that it opens and closes properly. Also, if needed, fit suitable protections or use proper safety sensors • If the operator is to be installed at a height of less than 2.5 m from the ground or other access level, make sure you have any necessary protections and/or warnings in place • Make sure that the opening automatic barrier does not constitute a hazard • Do not fit upside down or onto elements that could bend. If necessary, add suitable reinforcements to the anchoring points • Check that the temperature range shown on the operator is suitable for the climate where it is installed. • Do not install on tilted surfaces or slopes • Make sure any sprinkler systems cannot wet the operator from the ground up.

**Installing**

• Suitably section off and demarcate the entire installation site to prevent unauthorized persons from entering the area, especially minors and children • Be careful when handling operators that weigh over 20 kg. If need be, use proper safety hoisting equipment • The CE-marked safety devices (photocells, stepping plates, sensitive safety-edges, emergency buttons, and so on), must be fitted in compliance with the regulations in effect and according to state-of-the-art criteria, taking into account the environment, the type of required service and of the working forces applied to moving barriers. Any shearing or conveying points must be sensor-protected • Any residual risks must be clearly indicated • All opening commands (that is, buttons, key switches, magnetic readers, and so on) must be installed at least 1.85 m from the perimeter of the barrier's working area, or where they cannot be reached from outside the barrier. Also, any direct commands (buttons, touch panels, and so on) must be installed at least 1.5 m from the ground and must not be reachable by unauthorized persons • The automatic barrier must visibly show its identification data • Before connecting the main power supply make sure that the identification data correspond to the those of the network • The automatic barrier must be connected to an effective regulation grounding system.

• The manufacturer declines any liability for using non-original products; which would result in warranty loss • All maintained action commands, must be fitted in places from which the moving barrier and transit and driving areas are visible • Apply, if missing, a permanent sign showing the position of the release device • Before delivering to the users, make sure the system is EN 12453 and EN 12445 standard compliant (regarding impact forces), and also make sure the system has been properly adjusted and that any safety, protection and manual release devices are working properly • Apply Warning Signs where necessary and in a visible place, (such as, the gate's license plate)

**Special user-instructions and recommendations**

• Keep barrier operation areas clean and free of any obstructions. Make sure the photocell's operating field is clear of any obstructions • Do not allow children to play with fixed commands, or to loiter in the barrier's maneuvering area. Keep any remote control transmitters or any other command device away from children, to prevent the operator from being accidentally activated • The apparatus may be used by children of eight years and above and by physically, mentally and sensory-challenged people, or even ones without any experience, provided this happens under close supervision or once they have been properly instructed to use the apparatus safely and to the potential hazards involved. Children must not play with the apparatus. Cleaning and maintenance by users must not be done by children, unless properly supervised • Frequently check the system for any malfunctions or signs of wear and tear or damage to the moving structures, to the component parts, all anchoring points, including cables and any accessible connections. Keep any hinges, joints and friction points properly lubricated and clean of debris. • Perform functional checks on the photocells every six months.

Constantly clean the photocells' glass covers using a slightly water-moistened cloth; do not use solvents or chemicals that could damage the devices • If repairs or modifications are required to the system, release the operator and do not use it until safety conditions have been restored • Cut off the mains power supply before releasing the operator for manual openings. Read the instructions If the power supply cable is damaged, it must be replaced by the manufacturer or authorized technical assistance service, or in any case, by similarly qualified persons, to prevent any risk • It is FORBIDDEN for users to perform any OPERATIONS THAT ARE NOT EXPRESSLY REQUIRED OF THEM AND WHICH ARE NOT LISTED in the manuals. For any repairs, modifications and adjustments and for extra-ordinary maintenance, CALL TECHNICAL ASSISTANCE • Log the job and checks into the periodic maintenance log.

**Further recommendations for all**

• Keep away from and do not loiter near the barrier and mechanical moving parts • Do not enter the barrier's area of operation when it is moving • Do not counter the operator's movement as this could result in dangerous situations • Always pay special attention to any dangerous points, which have to be labeled with specific pictograms and/or black and yellow stripes • When using a selector switch or a command in maintained actions, keep checking that there are no persons within the operating range of any moving parts, until the command is released • The barrier may move at any time and without warning • Always cut off the power supply before performing any maintenance or cleaning.

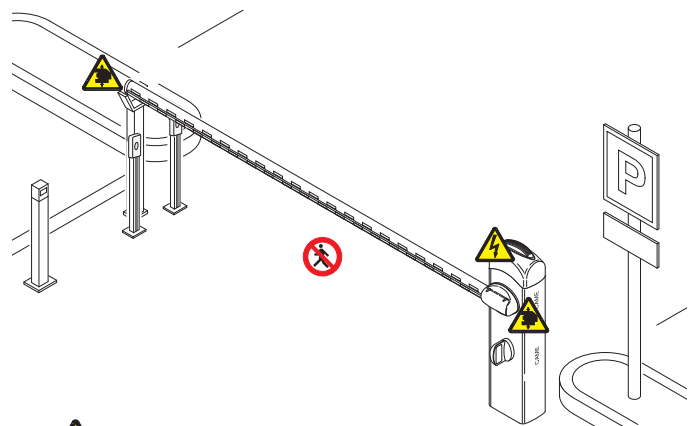

*Danger of hand crushing*





*Danger! High voltage.*



*No transiting while the barrier is moving*

## LEGEND

-  This symbol shows which parts to read carefully.
-  This symbol shows which parts describe safety issues
-  This symbol shows which parts to tell users about.

## REFERENCE REGULATIONS

Came S.p.A. is certified for the: ISO 9001 quality and ISO 14001 environmental management systems.  
This product complies with the current regulations mentioned in the declaration of conformity.

## DESCRIPTION

Barrier made of varnished galvanized steel or AISI 304 satin finished stainless steel, set up for accessories.

### Intended use

The automatic barrier is designed for private and public parking facilities, for residential areas and ones with heavy traffic, such as motorways.

 Any installation and/or use other than that specified in this manual is forbidden.

### Limits to use

Type	G3000DX - G3000SX - G3000IDX - G3000ISX
Maximum clearance width of the passage (m)	2.75

### Technical data

Type	G3000DX - G3000SX - G3000IDX - G3000ISX
Protection rating (IP)	54
Power supply (V - 50/60 Hz)	120 - 230 AC
Power supply motor (V)	24 DC
Draw (A)	15 max
Power (W)	300
Torque (Nm)	200
Opening time at 90° (s)	0.9
Duty cycle	INTENSIVE USE
Operating temperature (°C)	-20 ÷ +55
Reduction ratio (i)	1/202
Insulation class	I
Weight (kg)	47

### Dimensions (mm)

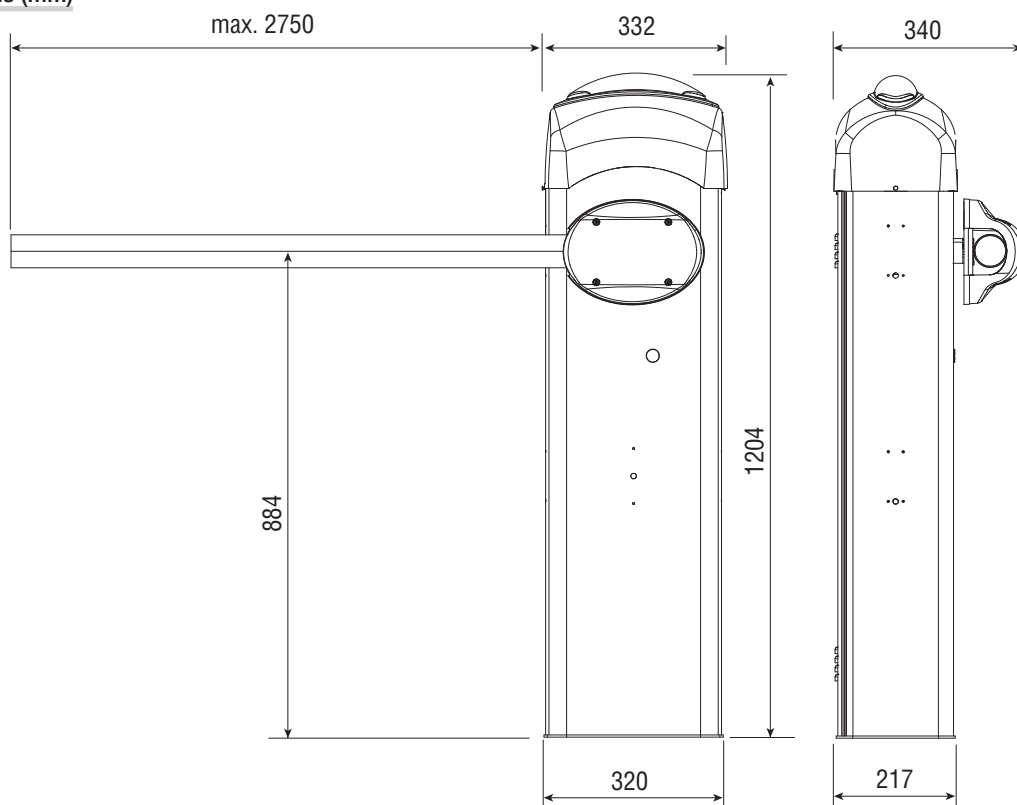

## Description of parts

- |                                 |                           |
|---------------------------------|---------------------------|
| 1. Dome                         | 9. Gearmotor with encoder |
| 2. Motor-shaft plate            | 10. Transformer           |
| 3. Release lock                 | 11. Release lever         |
| 4. Cabinet                      | 12. Inspection hatch      |
| 5. Control panel                | 13. Anchoring brace       |
| 6. Anchoring pin                | 14. Anchoring plate       |
| 7. Boom setting mechanical stop | 15. Anchoring brace       |
| 8. Lever arm                    |                           |

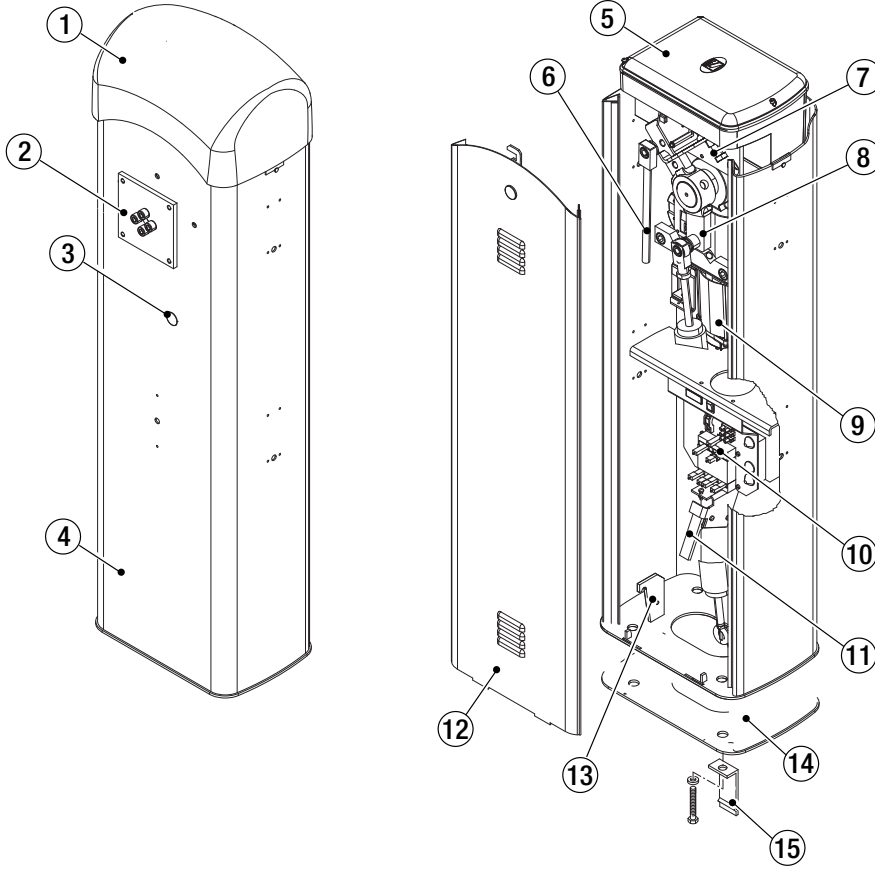

## Standard installation

- |                      |  |
|----------------------|--|
| 1. Barrier with boom | 7. Small photocell post                                  |
| 2. Reflective strips | 8. Fixed rest  |
| 3. Luminous cord     | 9. Coil  |
| 4. Flashing light    | 10. Control device post                                  |
| 5. Photocell casing  | 11. Control device (keypad selector, transponder sensor) |
| 6. Photocell         |  |

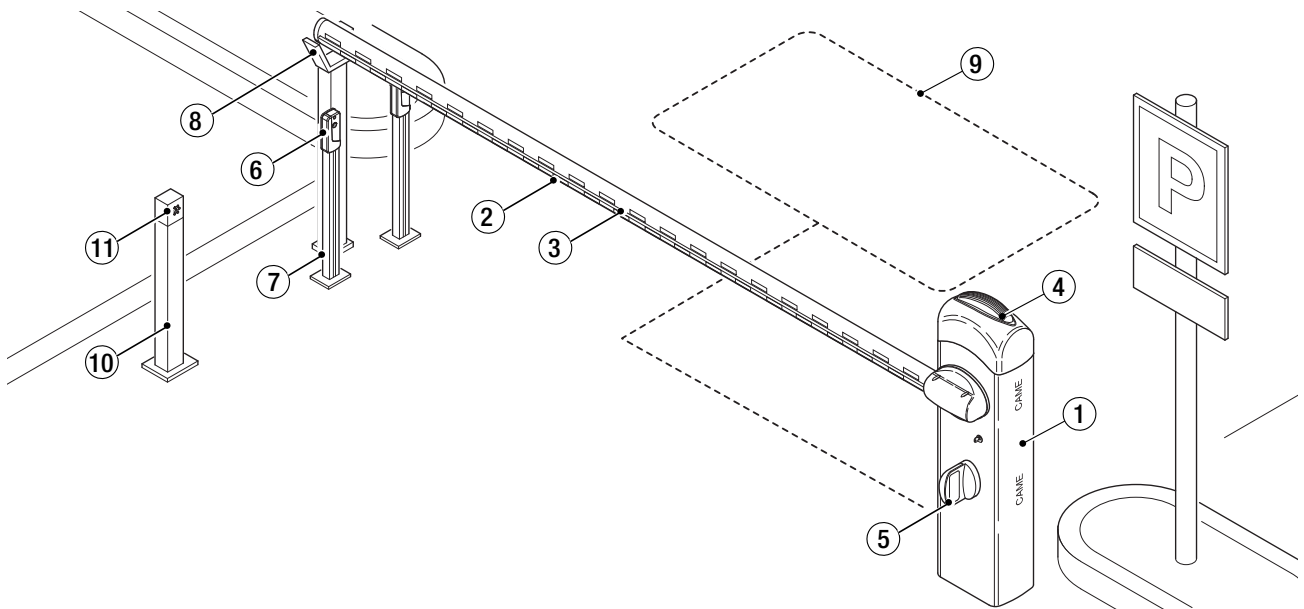

## GENERAL INSTRUCTIONS FOR INSTALLING

△ Only skilled, qualified staff must install this product.

Important! Using original CAME control and safety devices and accessories ensures easy installation and system maintenance.

### Preliminary checks

△ Before beginning, do the following:

- make sure the plate is anchored to a solid spot;
- make sure you have set up a suitable dual pole cut off device along the power supply that is compliant with the installation rules. It should completely cut off the power supply according to category III surcharge conditions (that is, with minimum contact openings of 3 mm);
- ⊕ make sure that any connections inside the casing (ones that ensure continuity to the protection circuit) are fitted with additional insulation with respect to those of other electrical parts inside;
- set up suitable tubes and conduits for the electric cables to pass through, making sure they are protected from any mechanical damage.

### Tools and materials

Make sure you have all the tools and materials you will need for installing in total safety and in compliance with applicable regulations. The figure shows some of the equipment installers will need.

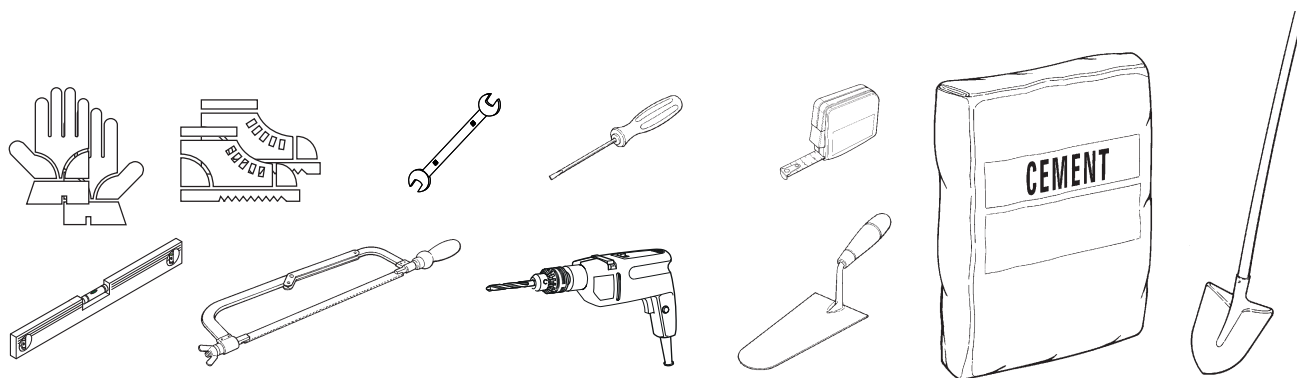

### Cable types and minimum thicknesses

Connection	Cable type	Cable length 1 < 10 m	Cable length 10 < 20 m	Cable length 20 < 30 m
Power supply 230 V AC	FROR CEI 20-22 CEI EN 50267-2-1	3G x 1.5 mm <sup>2</sup>	3G x 2.5 mm <sup>2</sup>	3G x 4 mm <sup>2</sup>
Flashing light		2 x 0.5 mm <sup>2</sup>	-	-
Photocell transmitters		2 x 0.5 mm <sup>2</sup>		
Photocell receivers		4 x 0.5 mm <sup>2</sup>		
Command and safety device		2 x 0.5 mm <sup>2</sup>		
Antenna	the RG58 antenna	max 10 m		
Metal mass detector		(see product literature)		

📖 If cable lengths differ from those specified in the table, establish the cable sections depending on the actual power draw of the connected devices and according to the provisions of regulation CEI EN 60204-1.

For multiple, sequential loads along the same line, the dimensions on the table need to be recalculated according to the actual power draw and distances. For connecting products that are not contemplated in this manual, see the literature accompanying said products

## INSTALLATION

△ The following illustrations are mere examples. Consider that the space available where to fit the barrier and accessories will vary depending on the area where it is installed. It is up to the installer to find the most suitable solution.

△ Warning! Use hoisting equipment to transport and position the barrier.

During the setting up and installing stages the barrier could be unstable and tip over. So, be careful to not lean on it until it is completely fastened.

### Preparing the fastening plate.

△ If the flooring does not allow for a sturdy anchoring of the cabinet, you will have to lay a cement slab.

Dig a hole for the foundation frame.

Set up the corrugated tubes needed for making the connections coming out of the junction pit.

📖 The number of tubes depends on the type of system and the accessories you are going to fit.

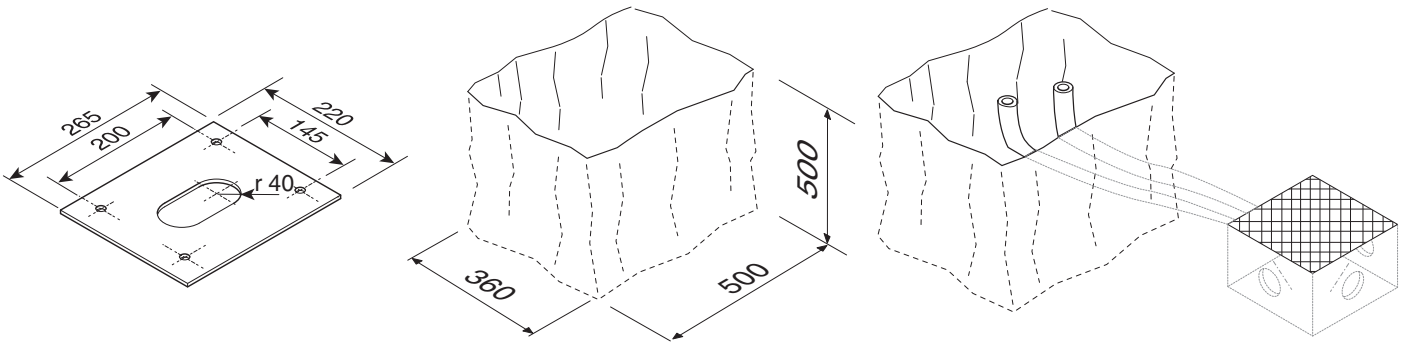

Set up a foundation frame that is larger than the anchoring plate and sink it into the dug hole.

Fit an iron cage into the foundation frame to reinforce the concrete.

Assemble the four anchoring braces to the anchoring plate.

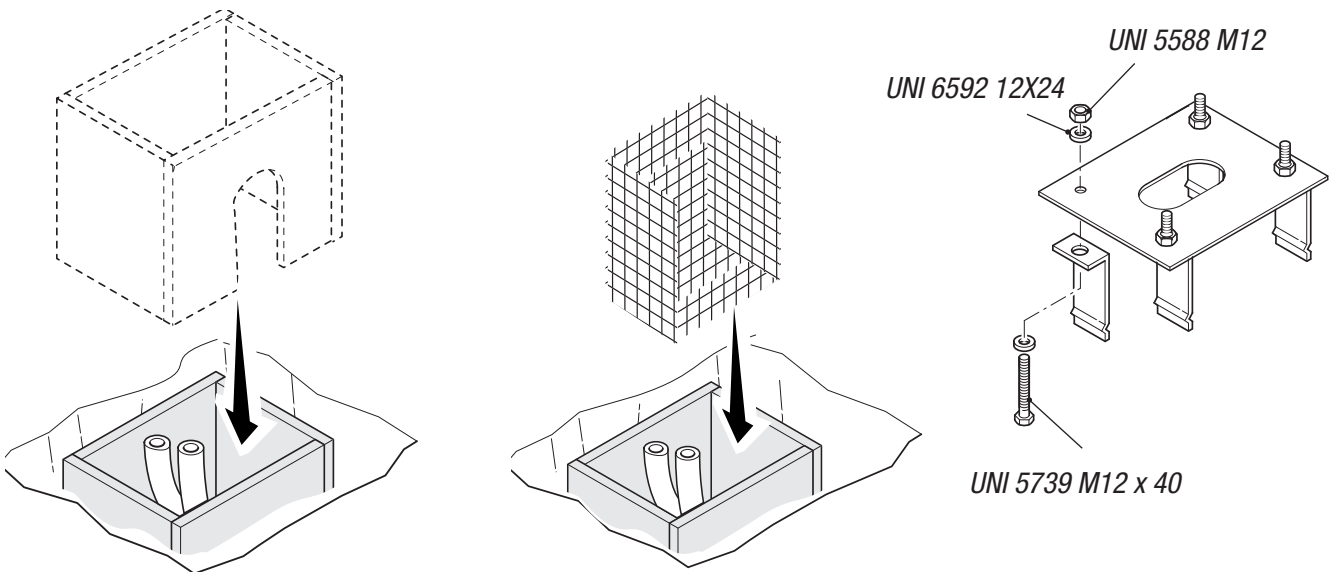

Place the plate over the iron cage.

Fill the foundation frame with concrete. The base must be perfectly level with the bolts which are entirely above surface.

Wait at least 24 hrs for the concrete to solidify.

Remove the foundation frame.

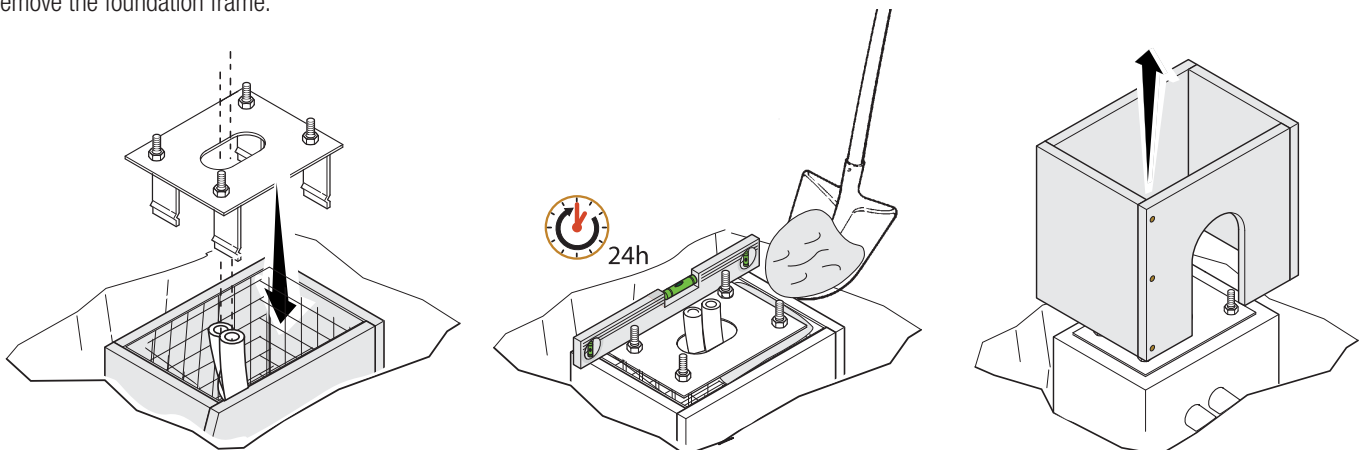

Fill the hole with earth around the concrete block.  
 Remove the nut and washer from the bolts  
 Fit the electric cables into the tubes so that they come out about 600 mm.

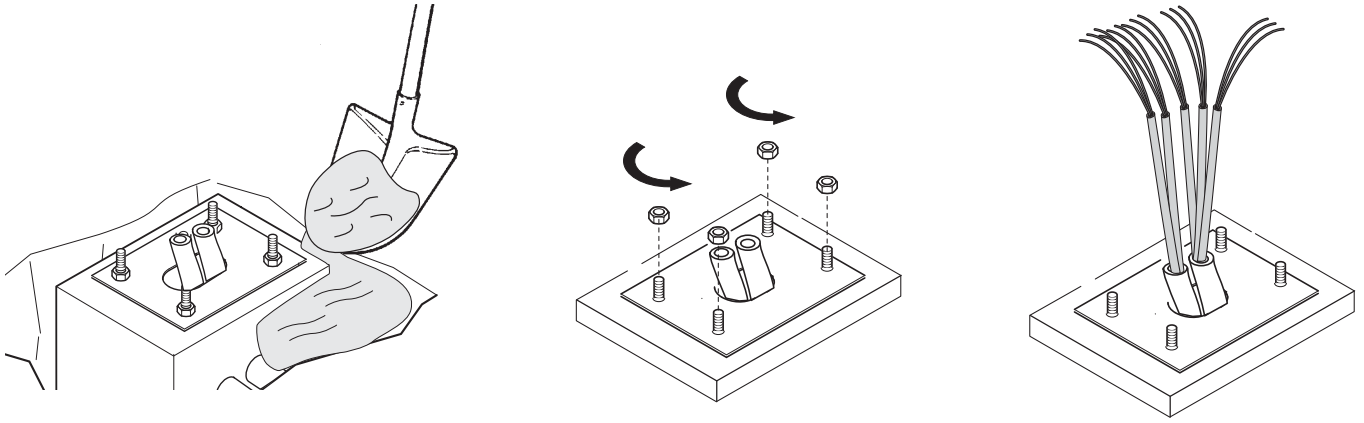

### Preparing the barrier

Remove the two screws on the top dome, fit the key into the lock and turn it counter clockwise ① ②.  
 Lift the dome and remove the inspection hatch ③.

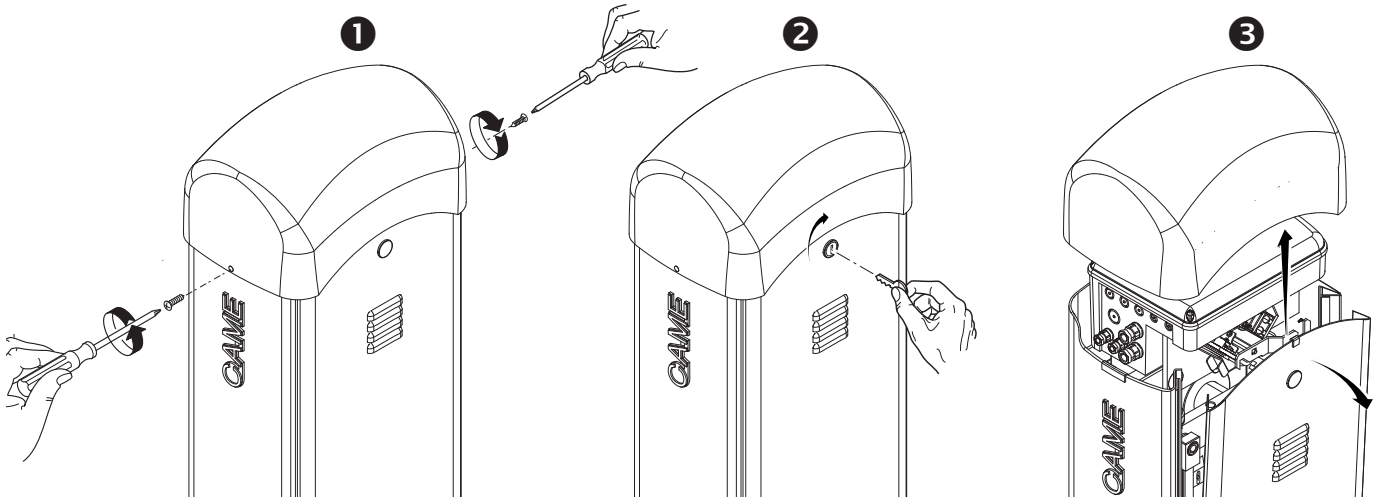

### Installing the barrier

 In this manual, the mounting operations are shown with a left barrier, for a right barrier proceed in symmetrical fashion.

**LEFT barrier**  
 (G3000SX - G3000ISX)

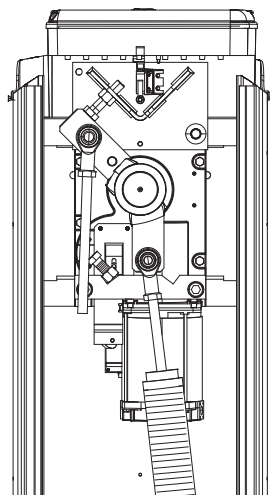

**RIGHT barrier**  
 (G3000DX - G3000IDX)

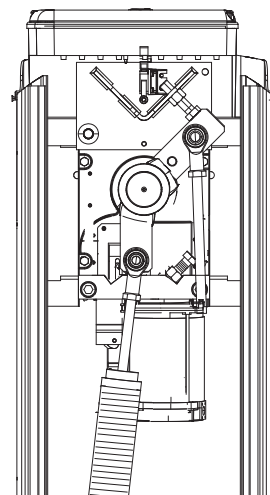

 The cabinet should be installed with the inspection hatch on the most accessible side to make any adjusting easier. Place the cabinet onto the anchoring plate and fasten it using nuts and washers.

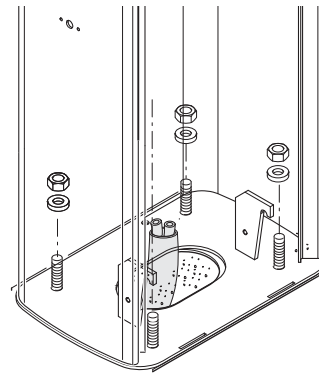
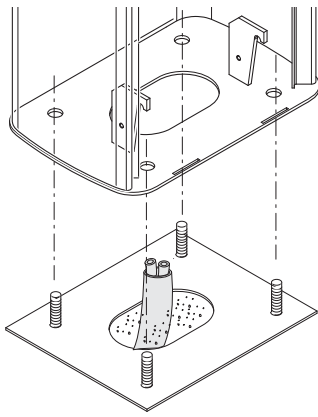

### Installing and balancing the boom

**⚠ For installing and balancing the G03001 boom, read the documentation for the G03003 accessory.  
For the G03002 boom, read the documentation for the G03004 accessory.**

### ELECTRICAL CONNECTIONS

**⚠ Warning!** Before working on the control panel, cut off the main current supply and, if present, remove any batteries.

Power supply to the control panel and control devices: 24 V AC/DC.

Functions on input and output contacts and time and user management details, are set up and viewable on the control panel's display. All connections are quick-fuse protected.

FUSE TABLE	ZL30
LINE - Line	5 A-F (120 V) 3.15 A-F (230 V)
C.BOARD - Card	1 A-F
MOTOR - Gearmotor	15 A-F
ACCESSORIES - Accessories	2 A-F

### Description of parts

- |                                |  |
|--------------------------------|--|
| 1. Motor fuse                  | 7. Programming warning LED                   |
| 2. Accessories fuse            | 8. Power supply on warning LED               |
| 3. Control board fuse          | 9. Gearmotor terminal                        |
| 4. Transformer terminal boards | 10. Terminals for control and safety devices |
| 5. AF card connector           | 11. Display                                  |
| 6. Programming buttons         |  |

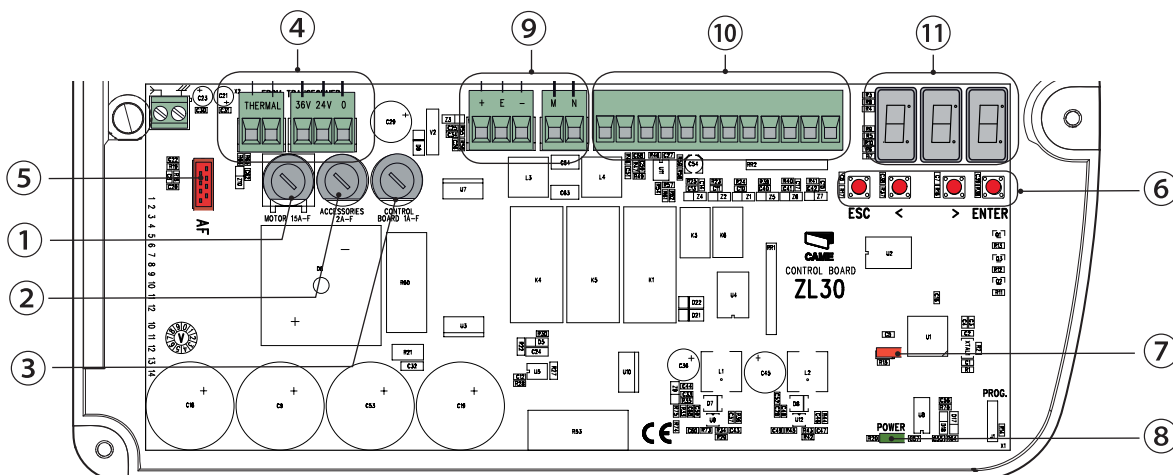

## Factory wiring

The gearmotor is already connected.

The illustration shows the connection for a left barrier. A right barrier, the cables on terminals M-N are inverted.

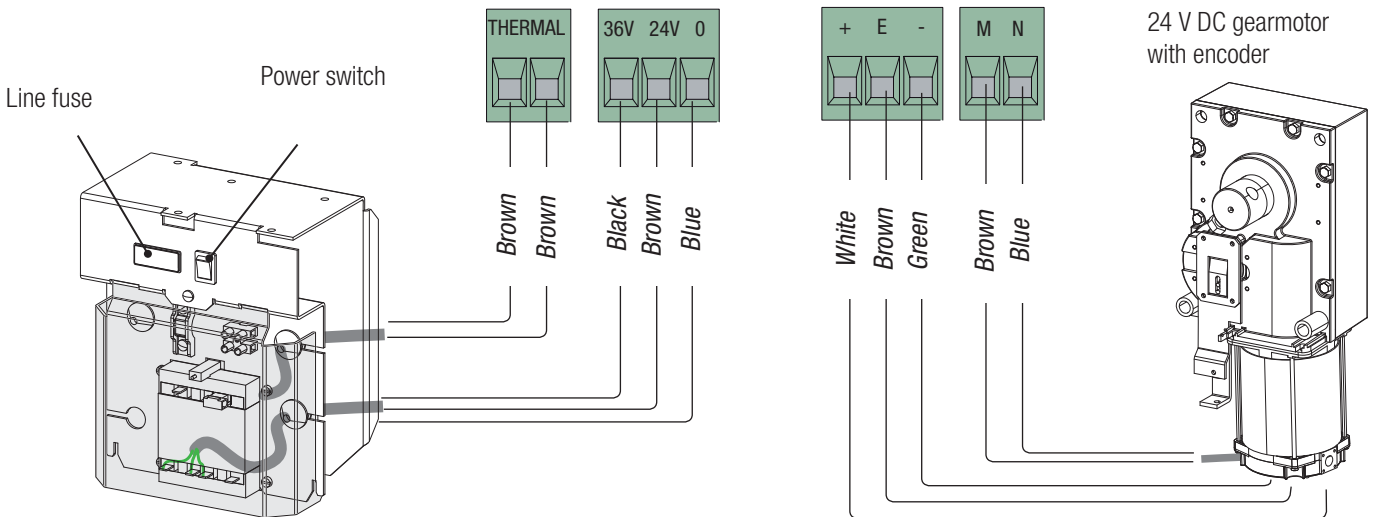

## Power supply

Before connecting up the mains power supply, remove the transformer protection.

UNI 6934  
Ø 3.9 x 9.5

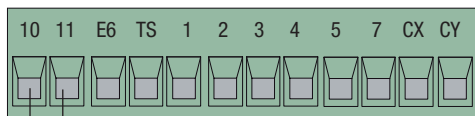
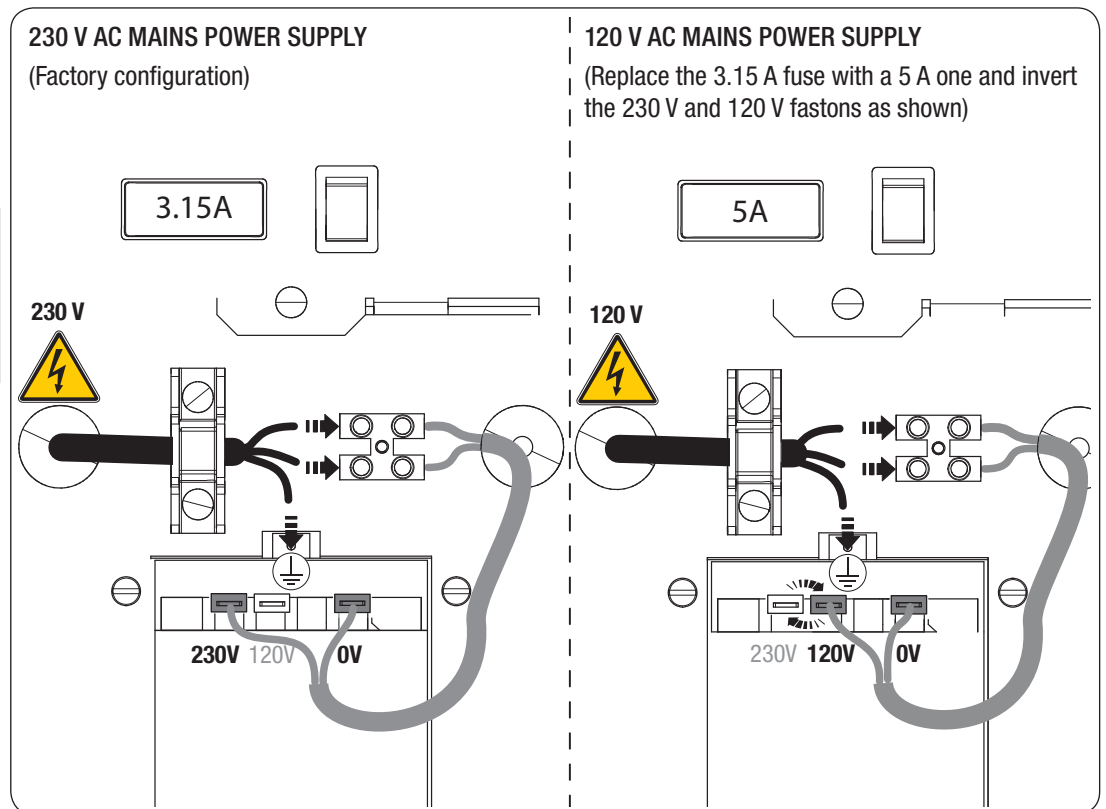
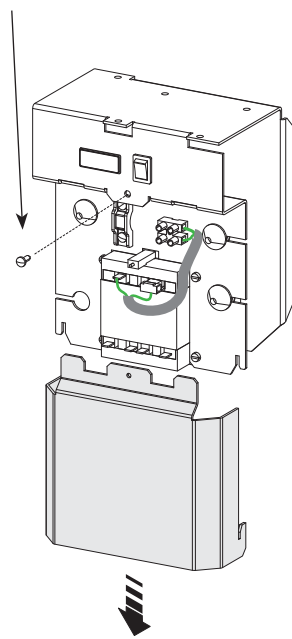

Terminals for powering up accessories:  
- at 24 V AC;  
Overall allowed power: 40 W

## Command and control devices

OPEN-CLOSE-INVERT function (step-step) from control device (NO contact).

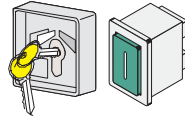

ONLY CLOSE function from control device (NO contact).  
Warning: in MAINTAINED ACTION mode, the control device must be connected to 2-4.

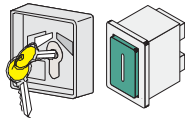

OPEN ONLY function from control device with NO contact.  
Warning: in MAINTAINED ACTION mode, the control device must be connected to 2-3.

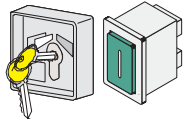

STOP button (NC contact). For stopping the boom while excluding the automatic closing. To resume movement either press the control button or any other control device.

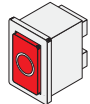

If unused, select 0 (Deactivated) from function F1.

Antenna with RG58 cable

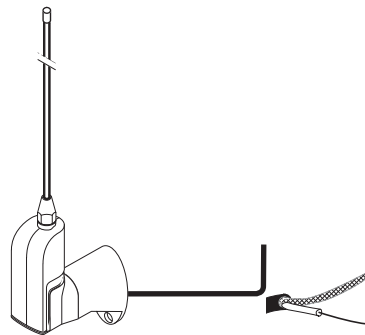

Fit the AF card to control the barrier with a transmitter.

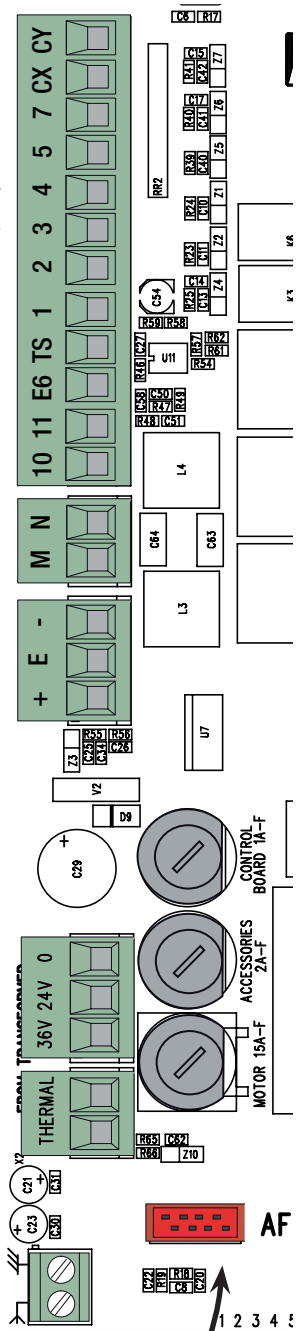
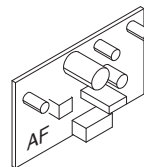

**WARNING! WARNING!** For the system to work properly, before fitting any plug-in card, such as the AF or R800 one, YOU MUST CUT OFF THE MAINS POWER SUPPLY and, if present, disconnect any batteries.

## Warning devices

Dome flashing light and/or luminous cord  
(Contact rated for: 24 V - 25 W max.)  
It flashes during the boom's opening and closing phases.

Barrier indicator light (contact rated for: 24 V AC - 3 W max.)  
It warns of the barrier status, see function F 10.

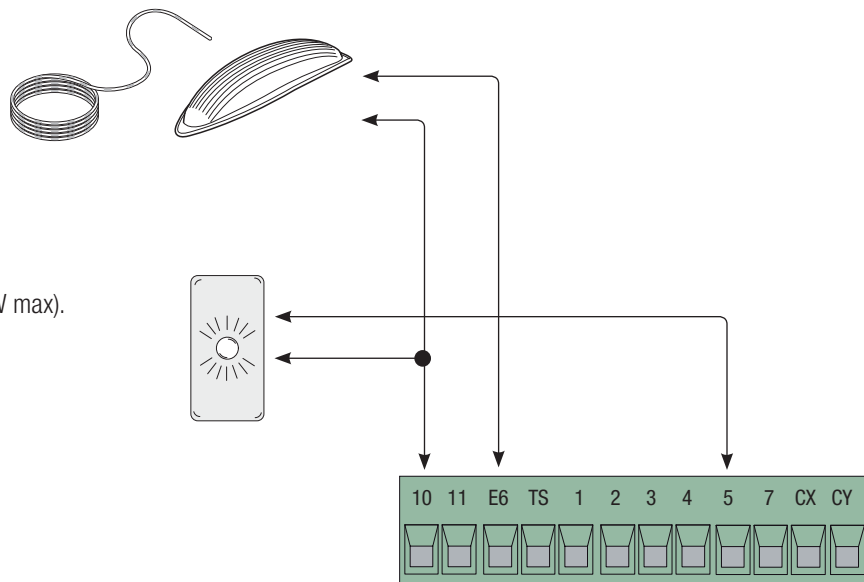

## Safety devices

Configure contact CX or CY (NC), input for safety devices such as photocells, that are EN 12978 regulation compliant. See CX input functions (Function F2) or CY (Function F3)-

**C1 reopening while closing.** When the boom is closing, opening the contact causes its movement to invert until fully opened;

**C4 obstruction wait.** Stopping the boom, if it is moving, with resumption of movement after the obstruction is removed.

**C5 immediate closing.** Closing the boom after a vehicle has passed through the operating area of the safety devices.

**C9 immediate closing with obstruction wait when closing.**

Closing the boom after a vehicle has passed through the operating area of the safety devices.

During the closing phase, the devices also perform the function of C4 obstruction wait.

If unused, contacts CX and CY should be deactivated during programming.

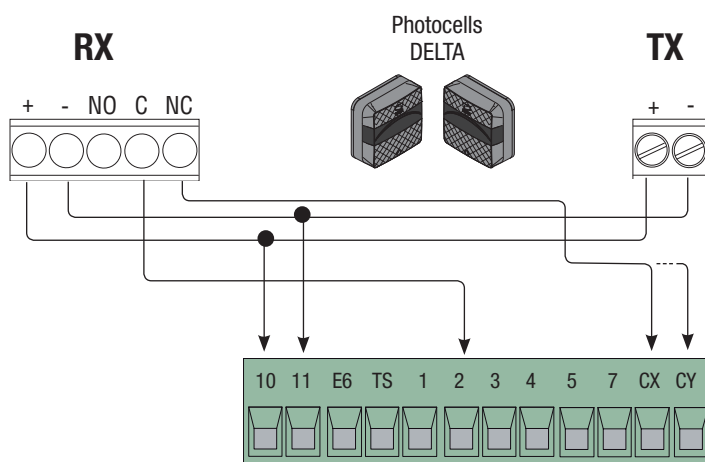
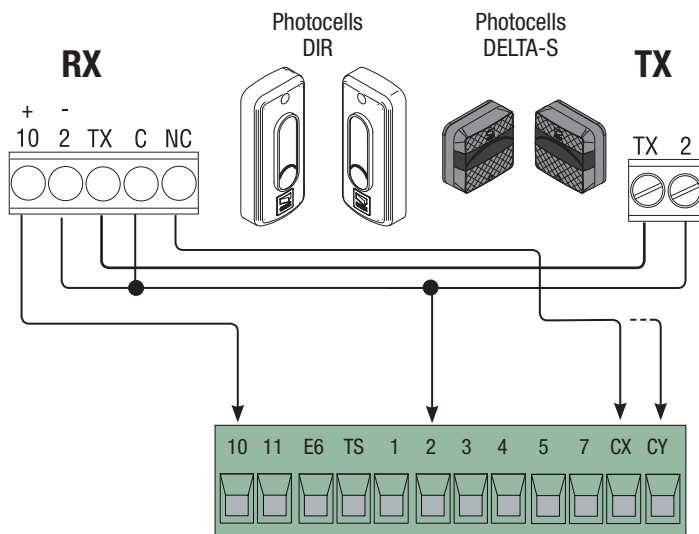

## Photocell's safety connection

At each opening and closing, the card checks whether the photocells are working. Any anomalies will inhibit all commands. Select, from Function F 5, on which inputs to activate.

### DELTA

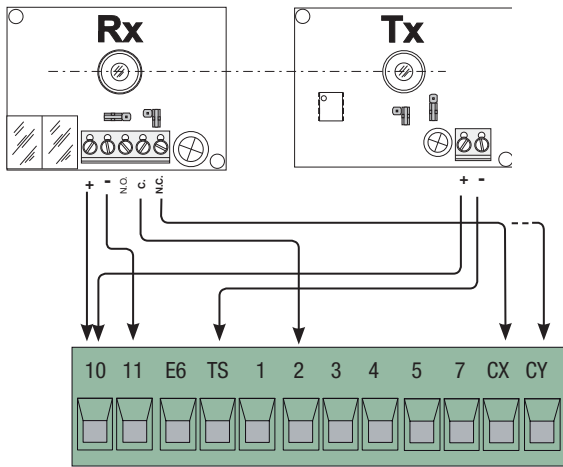

### DIR / DELTA S

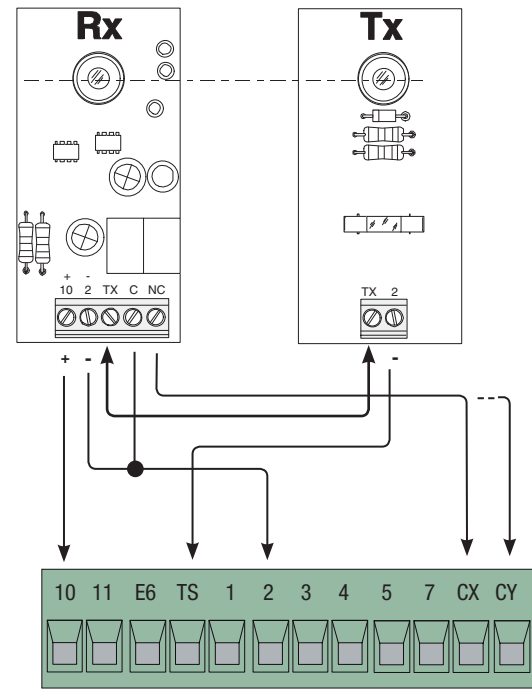

## Establishing the limit switch points

Close the inspection hatch and power up the system. Activate the barrier to check whether the boom is parallel to the road surface when closed and at about 89° when open.

⚠ The boom's opening and closing maneuvers must be performed with the inspection hatch closed.

To correct the boom's vertical position:

- lower the boom;
- open the inspection hatch;
- turn the opening mechanical stop clockwise to increase the boom's travel or counter clockwise to reduce it ❶.

Fasten the stop with a counter nut ❷.

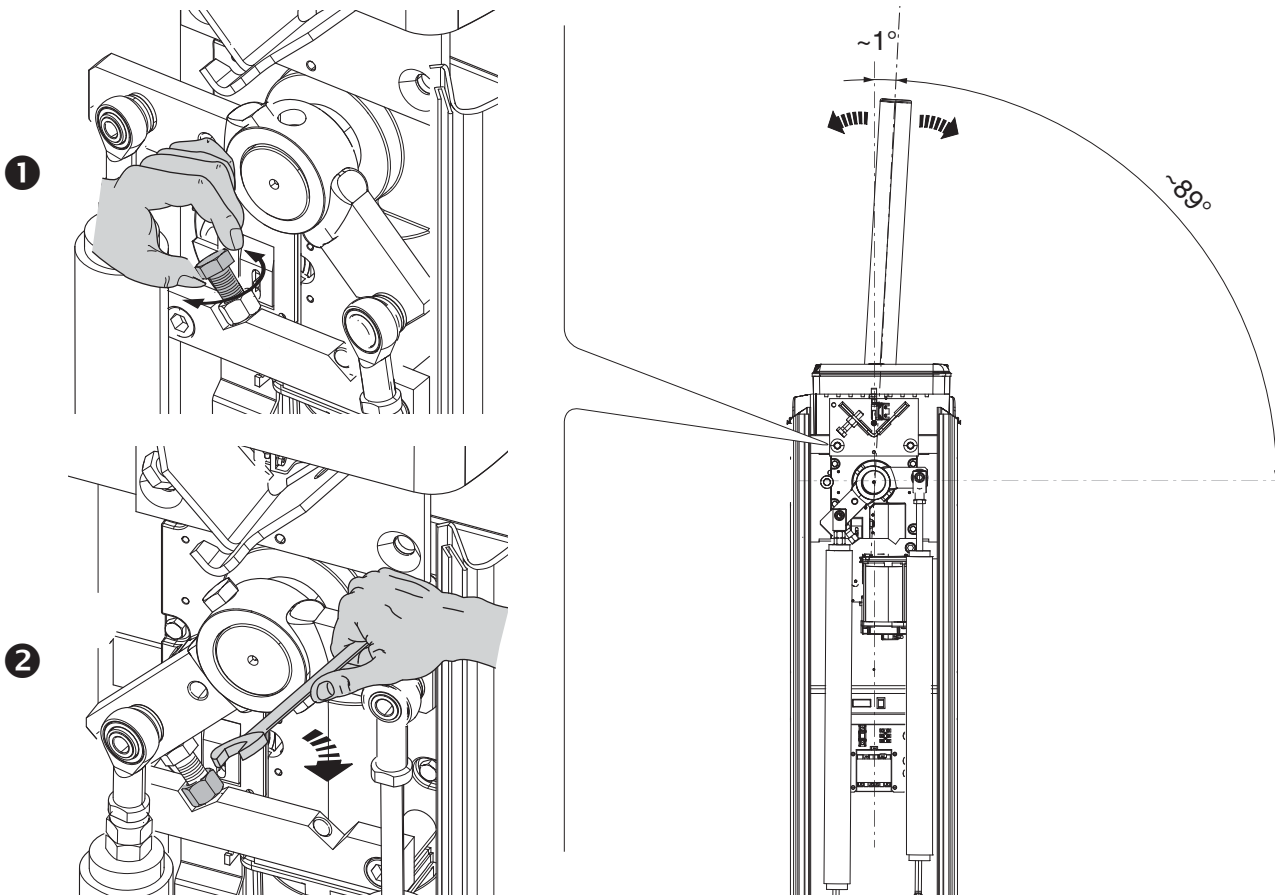

To correct the horizontal position:

- raise the boom;
  - turn the mechanical closing stop clockwise to increase the boom travel or counter clockwise to reduce it **3**.
- Fasten the stop with a counter nut **4**.

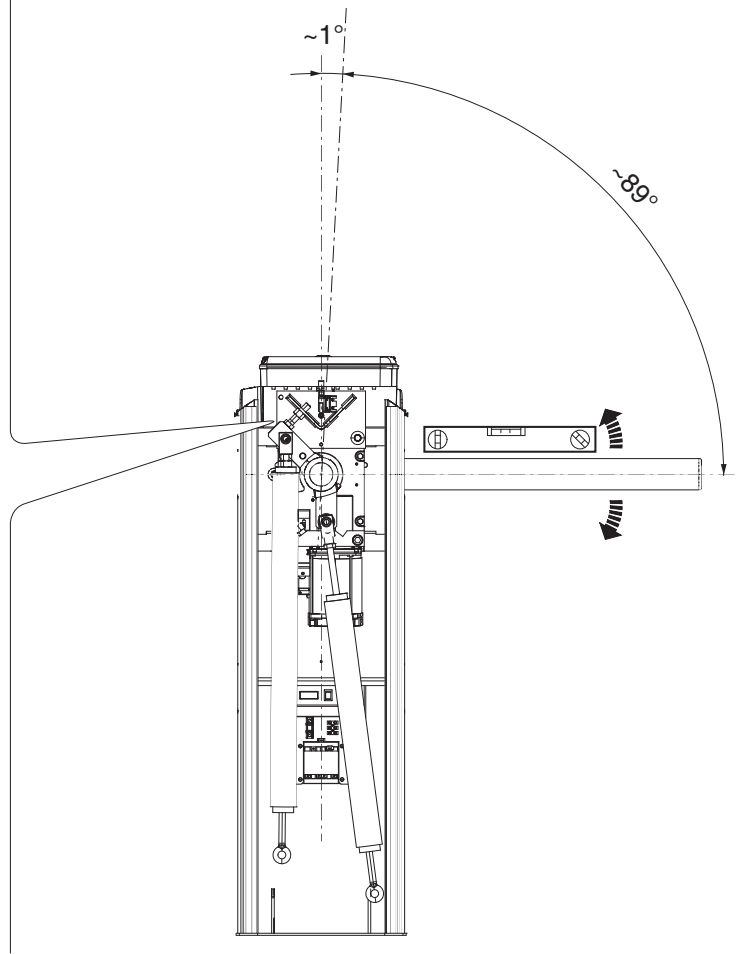
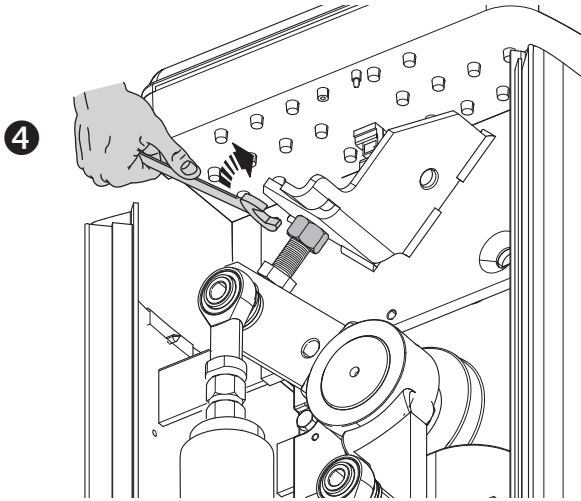
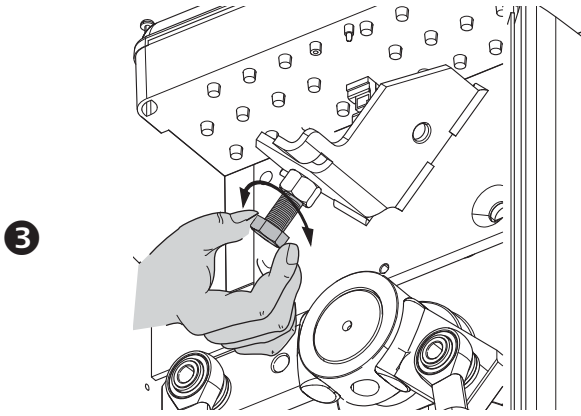

⚠ During programming, the barrier must not be moving.

Description of programming commands

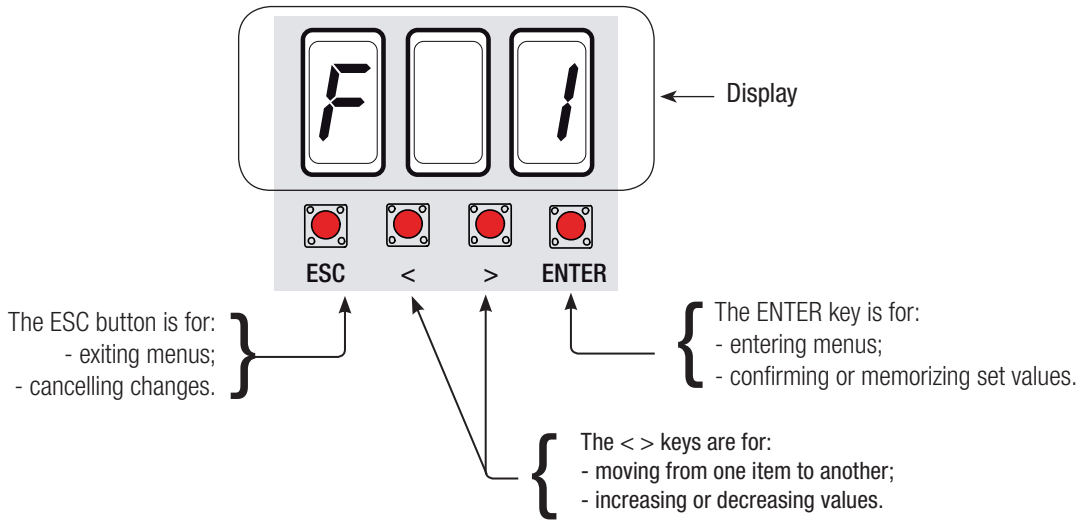

Browsing the menu

To enter the menu, keep the ENTER button pressed for at least one second.

To select menu items, use the arrow keys ...

... then press ENTER

also for the submenus, use the arrow keys to select ...

... then press ENTER

To increase or reduce the value use the arrows...

... then press ENTER to confirm ..

... to exit the menu, wait 10 seconds or press ESC.

## Functions map

F 1	Total stop function (1-2)	F 2	Function associated to input CX
F 3	Function associated to input CY		
F 5	Safety test function		
F 6	Maintained action function		
F 7	Control mode on 2-7		
F 9	Obstruction detection with motor idle function		
F 10	Warning light function		
F 15	Intermittent luminous cord function		
F 19	Automatic closing time		
F 21	Preflashing time		
F 22	Working time		
F 28	Adjusting opening speed		
F 29	Adjusting closing speed		
F 30	Adjusting opening slow-down speed		
F 31	Adjusting closing slow-down speed		
F 33	Adjusting calibration speed		
F 34	Sensitivity during movement		
F 35	Sensitivity during slow-down		
F 37	Adjusting the opening slow-down starting point		
F 38	Adjusting the closing slow-down starting point		
U 1	Type of command to associate to a user via radio control		
U 2	Deleting single users		
U 3	Deleting all users		
A 1	Setting the boom type		
A 2	Motor test		
A 3	Calibrating boom travel		
A 4	Resetting parameters		
A 5	Counting the number of maneuvers		
H 1	Software version		

## Functions menu

 **IMPORTANT! Start programming by first performing the following: A1 BOOM-TYPE SETTING, A2 MOTOR TEST, F1 TOTAL STOP and A3 CALIBRATING BOOM TRAVEL.**

<b>F1</b>	<b>Total stop [1-2]</b>	0 = Deactivated / 1 = Activated (default)
NC input - boom stop while excluding any automatic stop; to resume movement, use the control device. The safety device is to be fitted into [1-2]. If unused, deactivate the function.		
<b>F2</b>	<b>Input [2-CX]</b>	0 = Deactivated ( <b>default</b> ) / 1 = C1 / 4 = C4 / 5 = C5 / 9 = C9
NC input – Can associate: C1 = reopening during closing by photocells, C2 = reclosing during opening by photocells, C3 = partial stop, C4 = obstruction wait, C5 = immediate closing, C9 = immediate closing with obstruction wait during closing.		
<b>F3</b>	<b>Input [2-CY]</b>	0 = Deactivated ( <b>default</b> ) / 1 = C1 / 4 = C4 / 5 = C5 / 9 = C9
NC input – Can associate: C1 = reopening during closing by photocells, C2 = reclosing during opening by photocells, C3 = partial stop, C4 = obstruction wait, C5 = immediate closing, C9 = immediate closing with obstruction wait during closing.		
<b>F5</b>	<b>Safety test</b>	0 = Deactivated ( <b>default</b> ) / 1 = CX / 2 = CY / 3 = CX+CY
After every opening or closing command, the control board will check whether the photocells are working properly.		
<b>F6</b>	<b>Maintained action</b>	0 = Deactivated ( <b>default</b> ) / 1 = Activated
The barrier opens and closes by keeping one button pressed. Opening button on 2-3 and closing button on 2-4. When this function is activated, all other control devices, even radio ones, are excluded.		
<b>F7</b>	<b>Command [2-7]</b>	0 = step-step ( <b>default</b> ) / 1 = sequential
Step-step = open-close, sequential = open-stop-close-stop.		

<b>F9</b>	<b>Obstruction detection with motor idle</b>	0 = Deactivated ( <b>default</b> ) / 1 = Activated
With the barrier closed, open or after a total stop, the operator stays still if the safety devices (photocells and sensitive edges) detect an obstruction.		
<b>F10</b>	<b>Warning light</b>	0 = lit with boom raised and moving (default) / 1 = flashes intermittently each half second when opening when closing it flashes intermittently every second permanently lit with the boom raised off with the boom lowered
It warns of the barrier status. The light bulb is connected to 10-5.		
<b>F 15</b>	<b>Luminous cord intermittance</b>	0 = Moving boom (default) / 1 = Moving and closed boom
It warns of the status of the barrier with intermittent lights.		
<b>F19</b>	<b>Automatic closing time</b>	0 = Deactivated ( <b>default</b> ) / 1 = 1 s / 2 = 2 s / ... / 180 = 180 s
The first automatic-closing wait starts when the opening limit-switch point is reached and can be set to between 1 and 180 seconds. The automatic closing does not turn on if any of the safety devices trigger when an obstruction is detected, after a total stop or during a power outage.		
<b>F21</b>	<b>Preflashing time</b>	0 = Deactivated ( <b>default</b> ) / 1 = 1 s / ... / 10 = 10 s
After an opening or closing command, the flashing light connected to 10-E6, flashes from 1 to 10 seconds before the maneuver starts.		
<b>F22</b>	<b>Working time</b>	5 = 5 s / .... / 120 = 120 s ( <b>default</b> )
Gearmotor working time during opening and closing. The working time can be adjusted between 5 and 120 seconds.		
<b>F28</b>	<b>Opening maneuver speed</b>	60 = Minimum speed / ... / 80 = Speed ( <b>default</b> ) / ... / 100 = Maximum speed.
Setting the boom's opening speed, calculated as a percentage. △ Setting the speed between 90 and 100 automatically increases the percentage of the F 37 opening slow-down starting point.		
<b>F 29</b>	<b>Closing maneuver speed</b>	60 = Minimum speed / ... / 80 = Speed ( <b>default</b> ) / ... / 100 = Maximum speed.
Setting the boom's closing speed, calculated as a percentage. △ Setting the speed between 90 and 100 automatically increases the percentage of the F 38 closing slow-down starting point.		
<b>F 30</b>	<b>Opening slow-down speed</b>	10 = Minimum speed / ... / 15 = Speed ( <b>default</b> ) / ... / 30 = Maximum speed
Setting the boom's opening slow-down speed, calculated as a percentage.		
<b>F31</b>	<b>Closing slow-down speed</b>	10 = Minimum speed / ... / 15 = Speed ( <b>default</b> ) / ... / 30 = Maximum speed
Setting the boom's closing slow-down speed, calculated as a percentage.		
<b>F33</b>	<b>Calibration speed</b>	10 = 10% of the travel (minimum) / ... / 20 = 20% of the travel ( <b>default</b> ) / ... / 30 = 30% of the travel (maximum)
Setting the boom's travel automatic calibration, calculated as a percentage		
<b>F34</b>	<b>Boom travel sensitivity</b>	10 = maximum sensitivity / ... / 100 = minimum sensitivity ( <b>default</b> )
Adjusting obstruction detection sensitivity during boom travel.		
<b>F35</b>	<b>Slow-down sensitivity</b>	10 = maximum sensitivity / ... / 100 = minimum sensitivity ( <b>default</b> )
Adjusting obstruction detection sensitivity during slow-down.		
<b>F37</b>	<b>Opening slow-down point</b>	40 = 40% of the travel / ... / 50 = 50% of the travel ( <b>default</b> ) / ... / 70 = 70% of the travel
Percentage adjustment of the boom's total travel, from the beginning of the opening slow-down point.		
<b>F38</b>	<b>Closing slow-down point</b>	40 = 40% of the travel / ... / 50 = 50% of the travel ( <b>default</b> ) / ... / 60 = 60% of the travel
Percentage adjustment of the boom's total travel, from the beginning of the opening slow-down point.		
<b>U 1</b>	<b>Entering a user</b>	1 = Step-step command (open-close) / 2 = Sequential command (open-stop-close-stop) / 3 = Open only command
Up to a maximum of 25 users can be entered and each can be associated to a function of choice among those available. Entering is done via transmitter or other control device (see ENTERING USERS AND ASSOCIATED COMMANDS)		
<b>U 2</b>	<b>Deleting a user</b>	
To delete a user (see DELETING SINGLE USERS paragraph)		
<b>U 3</b>	<b>Deleting users</b>	0 = Deactivated / 1 = Deleting all users
Deleting all users.		

<b>A 1</b>	<b>Setting the boom type</b>	0 = Ø 60 mm tube boom / 1 = Semi-elliptic or elliptic boom
To establish the boom type.		
<b>A 2</b>	<b>Motor test</b>	0 = Disable / 1 = Activate
To verify the boom's proper rotating direction (see MOTOR TEST paragraph).		
<b>A 3</b>	<b>Calibrating boom travel</b>	0 = Disable / 1 = Activate
Automatic boom travel calibration (see CALIBRATING BOOM TRAVEL paragraph).		
<b>A 4</b>	<b>Resetting parameters</b>	0 = Disable / 1 = Activate
<b>Warning! If need be, the default parameters can be restored.</b> <b>The default settings are restored and the travel calibration deleted.</b> Restoring default settings and cancelling boom travel calibration operation.		
<b>A 5</b>	<b>Counting maneuvers</b>	
Show the number of completed maneuvers(--- = 0 maneuvers; 1 = 1,000 maneuvers; 100 = 100,000 maneuvers; ..... 999 = 999,000).		
<b>H 1</b>	<b>Version</b>	
View the software version.		

### Motor test

1. Select A 2. Press ENTER to confirm.

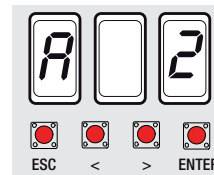

2. Select 1 to activate test. Press ENTER to confirm...

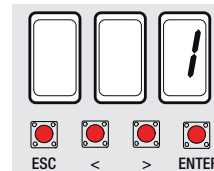

3. ... the dashes (---) will appear while waiting for the command.

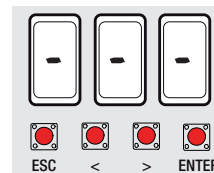

4. 4. Keep pressed the < key and check whether the barrier opens.

If the barrier closes, invert the motor phases (M with N).

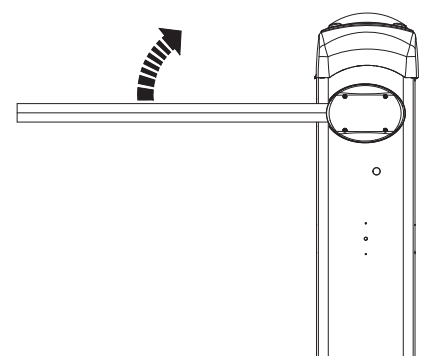
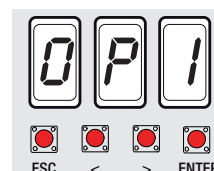

## Travel calibration

 Before doing a travel calibration, establish the boom type, check that the boom is balanced and that the maneuvering area is free of obstructions.

**Important!** During the calibration, all safety devices will be disabled except for the PARTIAL STOP.

1. Select A 3.

Press ENTER to confirm.

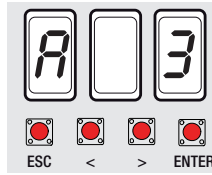

2. Select 1 and press ENTER to confirm the travel calibration operation.

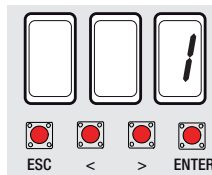

3. The barrier will perform a closing maneuver until the limit-switch point...

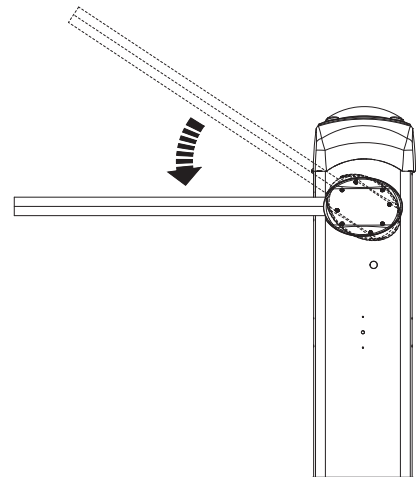
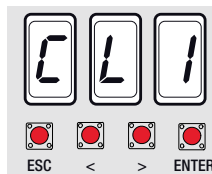

4. then, the barrier will perform an opening maneuver until the limit-switch point.

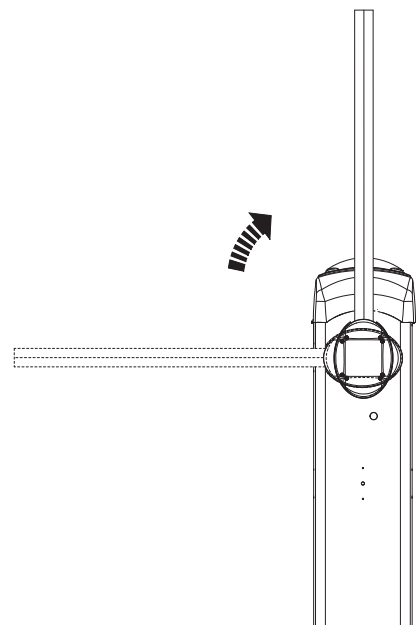
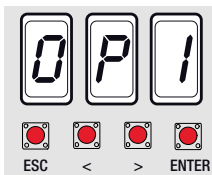

 When entering/deleting users, the flashing numbers that appear, are numbers that can be used for other users you may wish to enter (maximum 25 users).

### Entering a user with an associated command

1. Select U 1.  
Press ENTER to confirm.

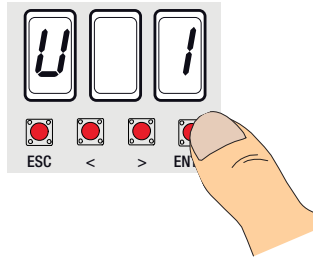

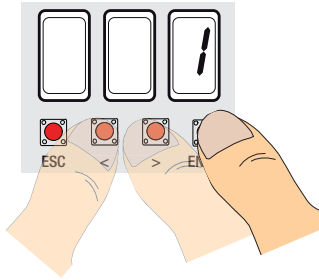

2. Select a command to associate to the user.  
The commands are:  
- step-step (open-close) = 1;  
- sequential command (open-stop-close-stop) = 2;  
- open = 3.

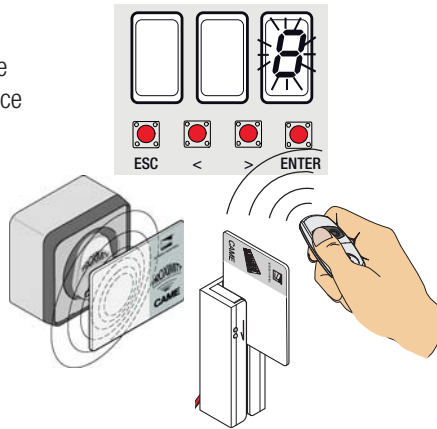

3. ... an available number between 1 and 25 will flash for a few seconds. This number is then assigned to the user after having sent the code with the transmitter or other control device (sensor, card reader or keypad selector).



User	Associated command
1 - 	
2 - 	
3 -	
4 -	
5 -	
6 -	
7 -	
8 -	
9 -	
10 -	
11 -	
12 -	
13 -	
14 -	
15 -	
16 -	
17 -	
18 -	
19 -	
20 -	
21 -	
22 -	
23 -	
24 -	
25 -	

### Deleting a single user

1. Select U 2.  
Press ENTER to confirm.

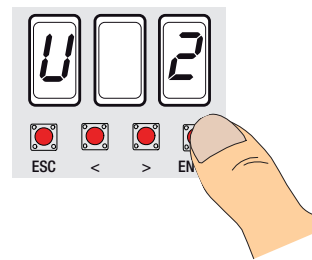

2. Select the user number to delete by using the arrow keys. Press ENTER to confirm...

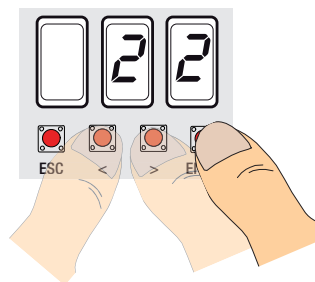

3. ... the abbreviation CLr will appear to confirm the user has been deleted.

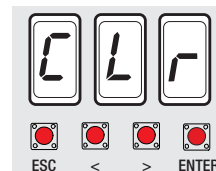

## FINAL OPERATIONS

When you are done with the electrical connections and setting up, fit the hatch and fasten it with the screws **1**.  
Clock the hatch with the key. Fasten the dome using the screws **2 3**.

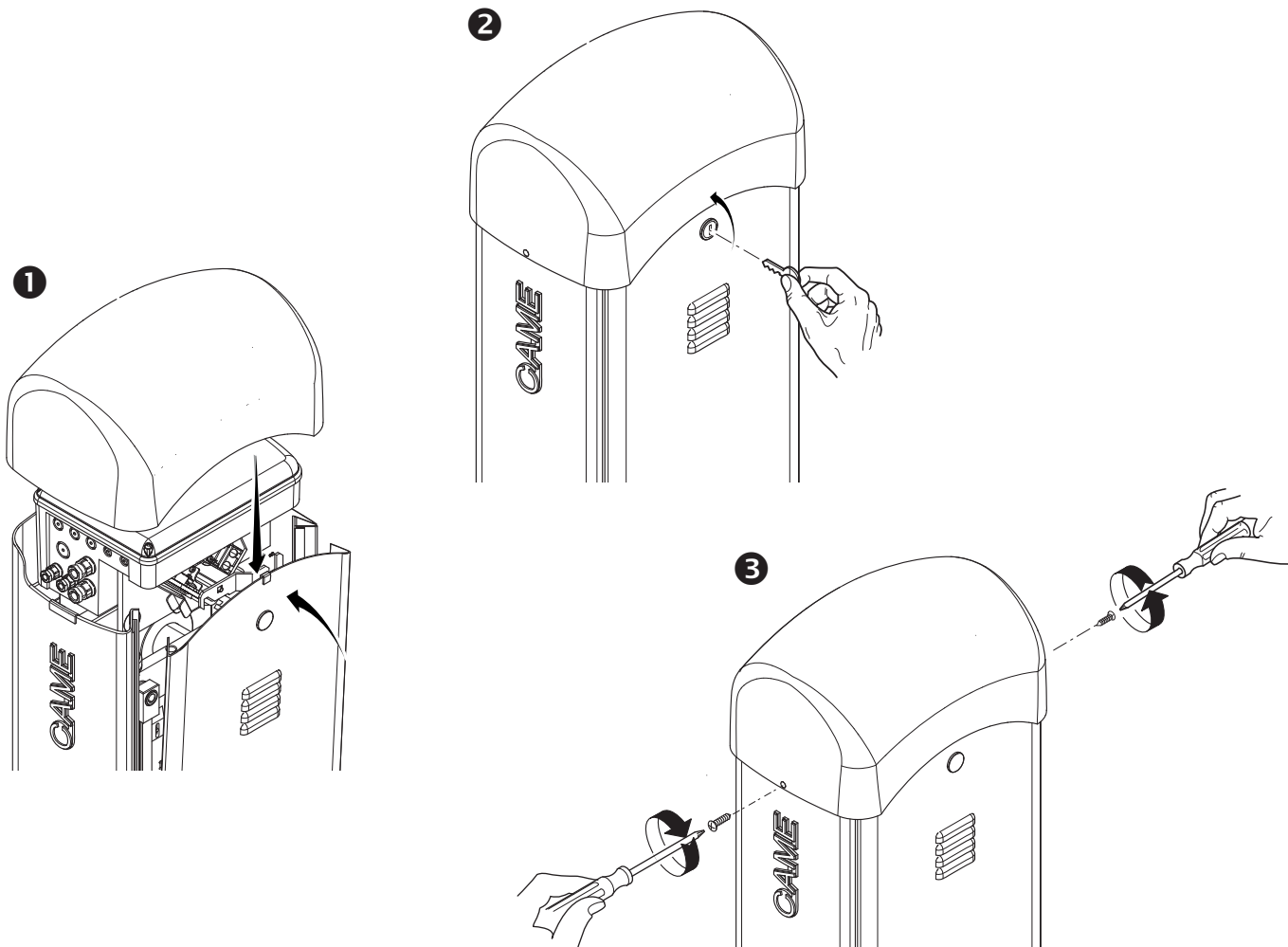

## RELEASING THE BOOM

⚠ This procedure must be done with the mains power cut off.  
Fit the key into the lock and turn it clockwise. Manually lift the boom and lock it again by turning the key counter clockwise **1 2**.

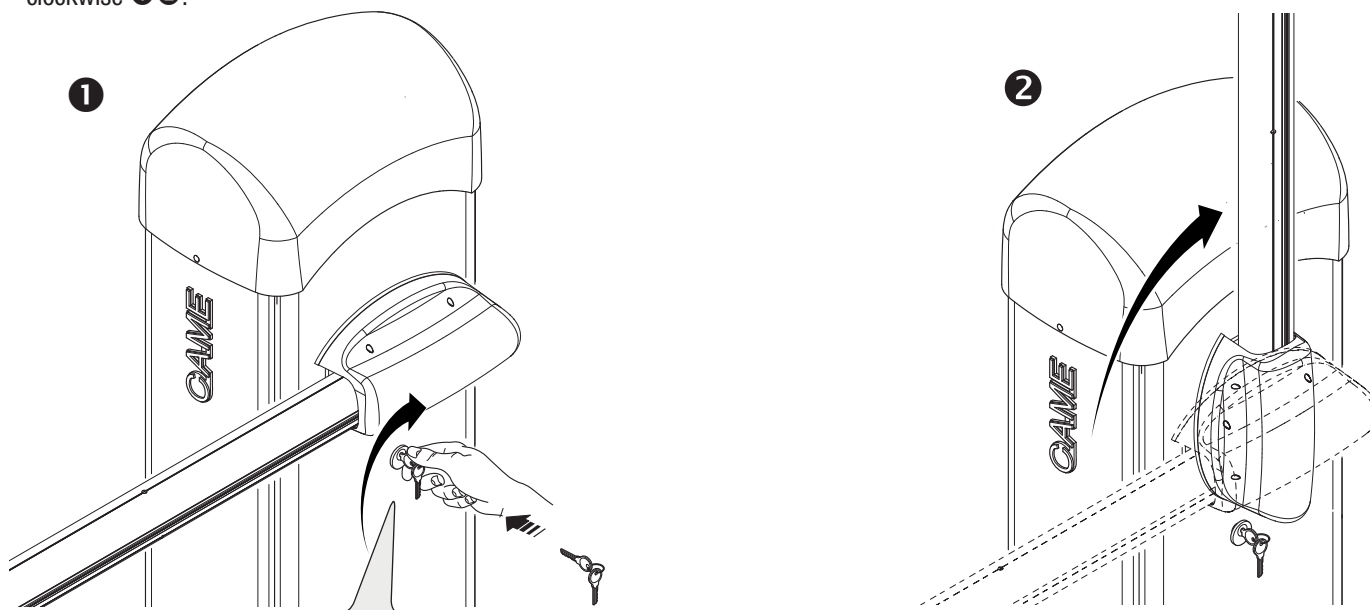

⚠ **WARNING!** This release procedure is potentially hazardous for users, when for whatever reason, such as the boom being badly fastened, ripped out or broken during an accident, and so on, the loosened springs no longer provide the proper balancing action. This could lead to a sudden rotation of the boom attachment and/or of the boom itself.

△ If the key is not enough to release the boom from the gearmotor, you will have to remove the dome, open the inspection hatch and pull on the release lever under the transformer ③④.

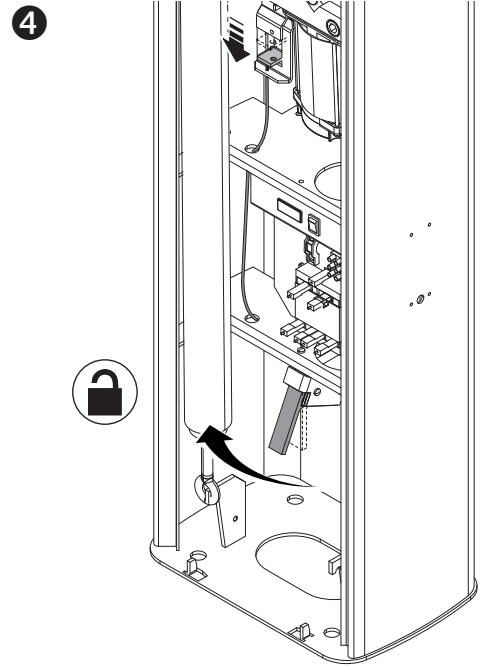
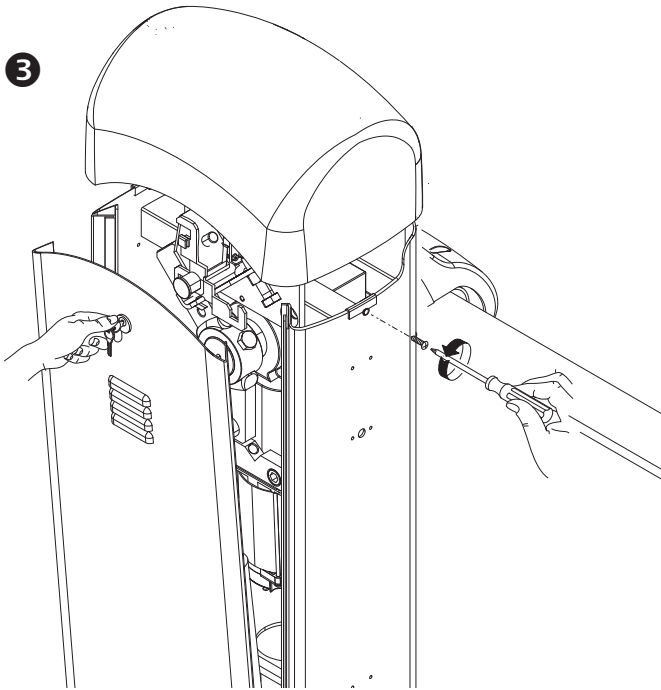

Manually lift the boom and lock it again by moving back the lever ⑤⑥.

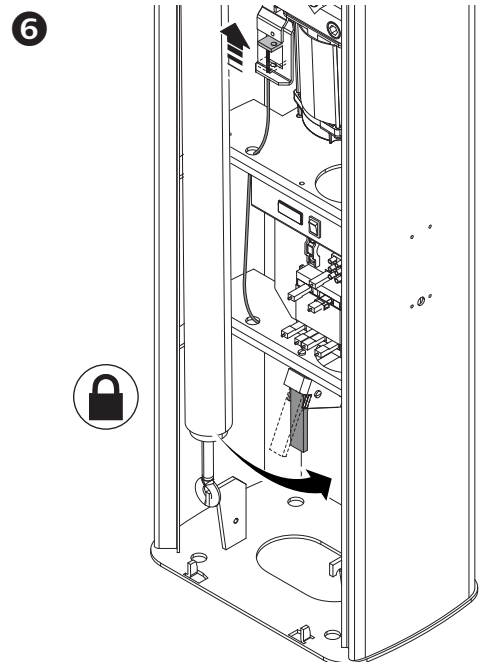
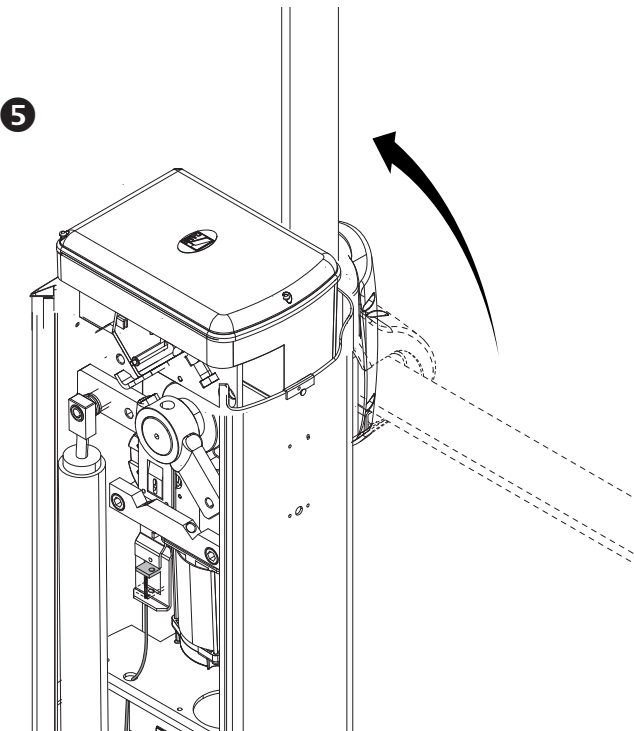

### ERROR MESSAGE

📖 The error messages appear on display or are notified by the LEDs.

Er1	The boom travel calibration was interrupted by the activation of the STOP button.
Er3	Encoder is broken.
Er4	Services test error.
Er5	Insufficient working time
Er6	Maximum number of obstructions detected.
Er7	Transformer overheating.
Er8	The inspection hatch is open.
C0	Contact 1-2 (NC) is open.
C1, C4, C5 or C9	The (NC) contacts are open.
The warning LED flashes	The control board is not yet calibrated for the boom travel.



## Extraordinary maintenance

- △ The following table is for logging any extraordinary maintenance jobs, repairs and improvements performed by specialized contractors.  
📖 Any extraordinary maintenance jobs must be done only by specialized technicians.

### Extraordinary maintenance log

Fitter's stamp	Name of operator
	Job performed on (date)
	Technician's signature
	Requester's signature
Job performed _____ _____	

Fitter's stamp	Name of operator
	Job performed on (date)
	Technician's signature
	Requester's signature
Job performed _____ _____	

Fitter's stamp	Name of operator
	Job performed on (date)
	Technician's signature
	Requester's signature
Job performed _____ _____	

## DISMANTLING AND DISPOSAL

- 👉 CAME CANCELLI AUTOMATICI S.p.A. applies a certified Environmental Management System at its premises, which is compliant with the UNI EN ISO 14001 standard, to ensure the environment is safeguarded.  
Please continue safeguarding the environment. At CAME we consider it one of the fundamentals of our operating and market strategies. Simply follow these brief disposal guidelines:

### ♻️ DISPOSING OF THE PACKAGING

The packaging materials (cardboard, plastic, and so on) should be disposed of as solid household waste, and simply separated from other waste for recycling.

Always make sure you comply with local laws before dismantling and disposing of the product.

**DO NOT DISPOSE OF IN NATURE!**

### ♻️ DISMANTLING AND DISPOSAL

Our products are made of various materials. Most of these (aluminum, plastic, iron, electrical cables) are classified as solid household waste.

They can be recycled by separating them before dumping at authorized city plants.

Whereas other components (control boards, batteries, transmitters, and so on) may contain hazardous pollutants.

These must therefore be disposed of by authorized, certified professional services.

Before disposing, it is always advisable to check with the specific laws that apply in your area.

**DO NOT DISPOSE OF IN NATURE!**

## DECLARATION OF CONFORMITY

**Declaration CE** - CAME Cancelli Automatici S.p.A. declares that this device conforms to the essential, pertinent requirements provided by directives 2006/42/CE and 2004/108/CE.

*An original copy of the declaration of conformity is available on request.*

Manual code: **FA00028-EN v.1** - 05/2015 - © Came S.p.A.  
The contents of this manual may be changed at any time without prior notice.

**CAME**  
safety & comfort

CAME *bpt*   
*parkare*

